

Agri-Fab®

OWNERS MANUAL

Model No.
45-01751

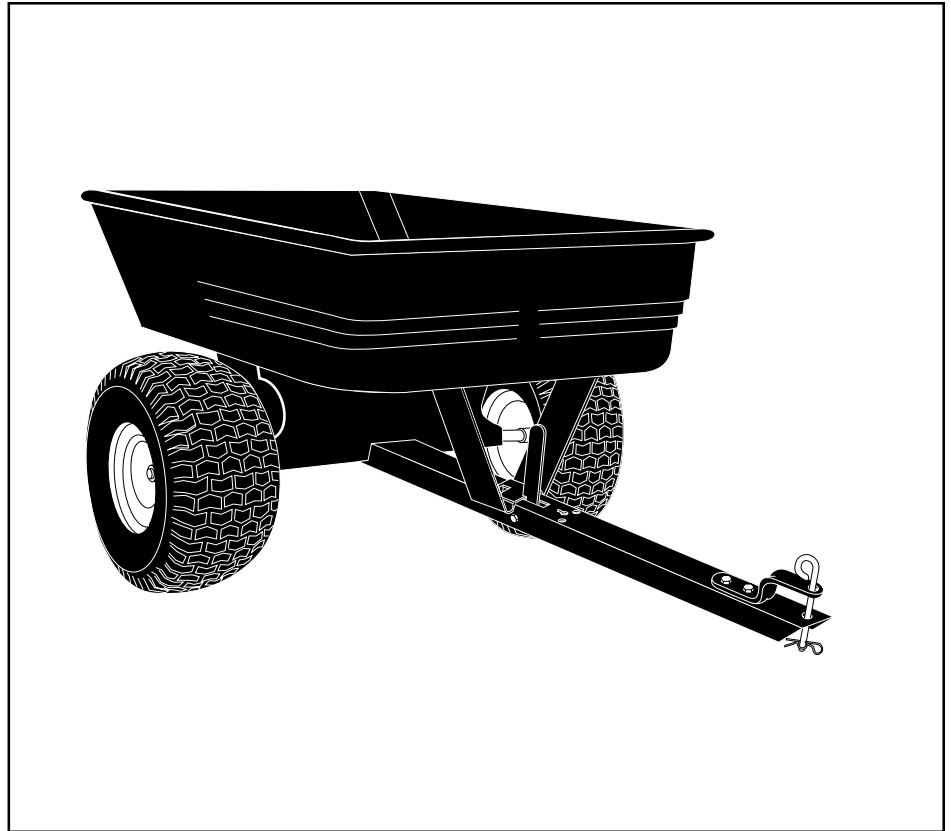

EXPLORER POLY ATV CART

IMPORTANT!

The wheel bearings are not prelubricated.
The wheel hubs must be filled with grease after the
wheels are assembled to the axle.

CAUTION:
Read Rules for
Safe Operation
and Instructions
Carefully

- Assembly
- Operation
- Maintenance
- Repair Parts

SpeedEPart *the fastest way to purchase parts* www.speedepart.com

SAFETY RULES

Remember, any power equipment can cause injury if operated improperly or if the user does not understand how to operate the equipment. Exercise caution at all times when using power equipment.

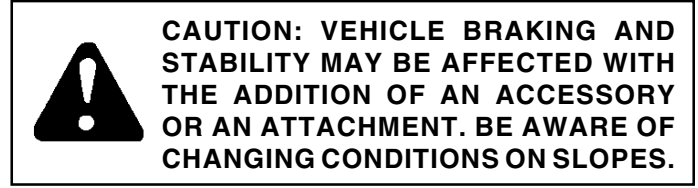

Exercise caution at all times when using power equipment.

- Read this owners manual before attempting to assemble or operate the cart.
- Read the vehicle owners manual and know how to operate your vehicle before using the cart attachment.
- Do not at any time carry passengers in this cart. It has not been designed to carry passengers.
- Never allow children to operate the vehicle or the cart attachment.
- Do not allow adults to operate the vehicle or cart attachment without proper instructions.
- Always begin with the transmission in first (low) and gradually increase speed as conditions permit.
- Tow the cart at reduced speed over rough terrain and hillsides or near creeks and ditches to prevent tipping over and loss of control. Do not drive too close to a creek or ditch.
- Vehicle braking and stability may be affected with the attachment of this cart. Do not fill cart to maximum weight capacity without checking the capability of the towing vehicle to safely pull and stop with the cart attached.
- Before operating vehicle on any grade (hill) refer to the safety rules in the vehicle owner's manual concerning safe operation on slopes. Refer also to the slope guide on page 11 of this manual. **Stay off steep slopes!**
- Do not tow this cart on highways or on public thoroughfares.
- Maximum towing speed is 10 m.p.h.
- Follow maintenance and lubrication instructions as outlined in this manual.

CARTON CONTENTS (Loose Parts)

- | | | |
|------------------------|--------------------|---------------------|
| 1. Poly Tray | 5. Axle | 8. Latch Lock Lever |
| 2. Wheel Support | 6. Wheels (2) | 9. Hitch Bracket |
| 3. Latch Stand Plate | 7. Draw Bar Tongue | |
| 4. Latch Stand Bracket | | |

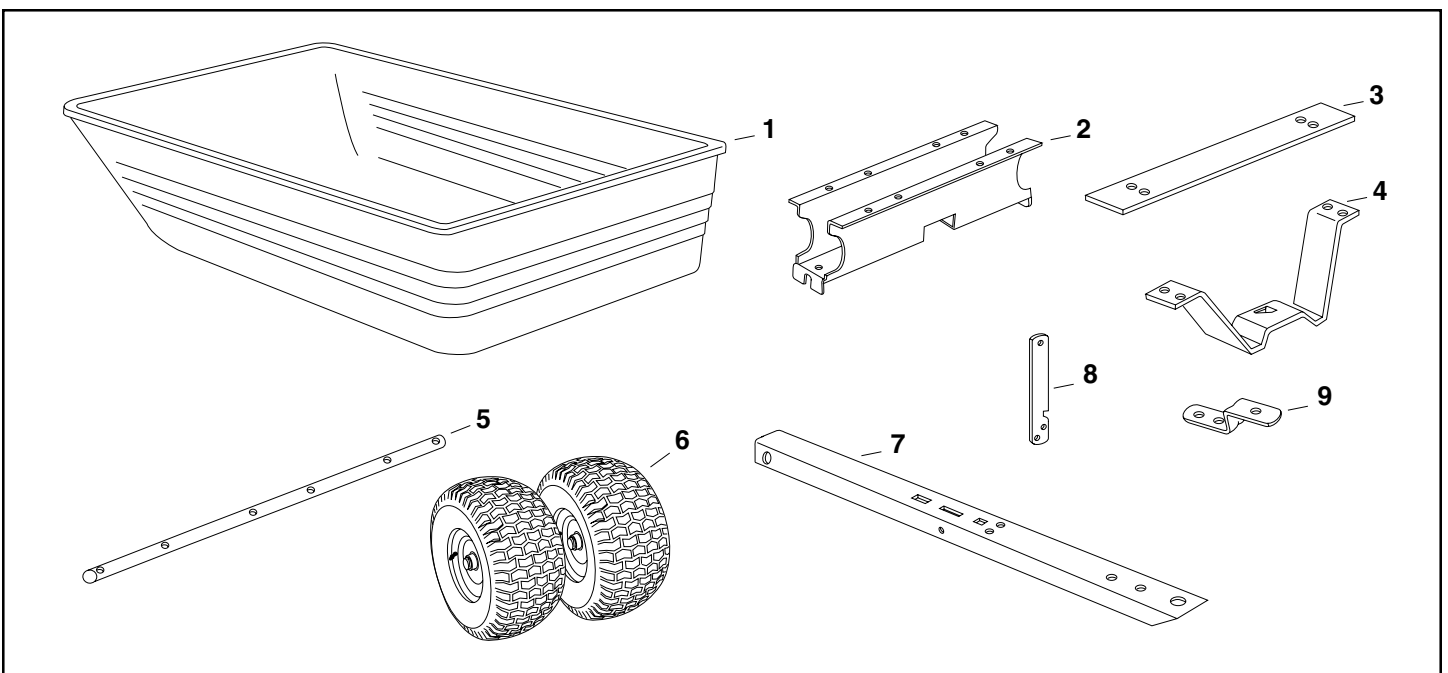

CARTON CONTENTS

HARDWARE SHOWN FULL SIZE

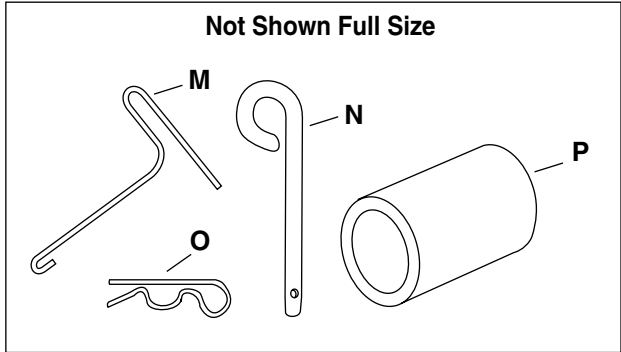
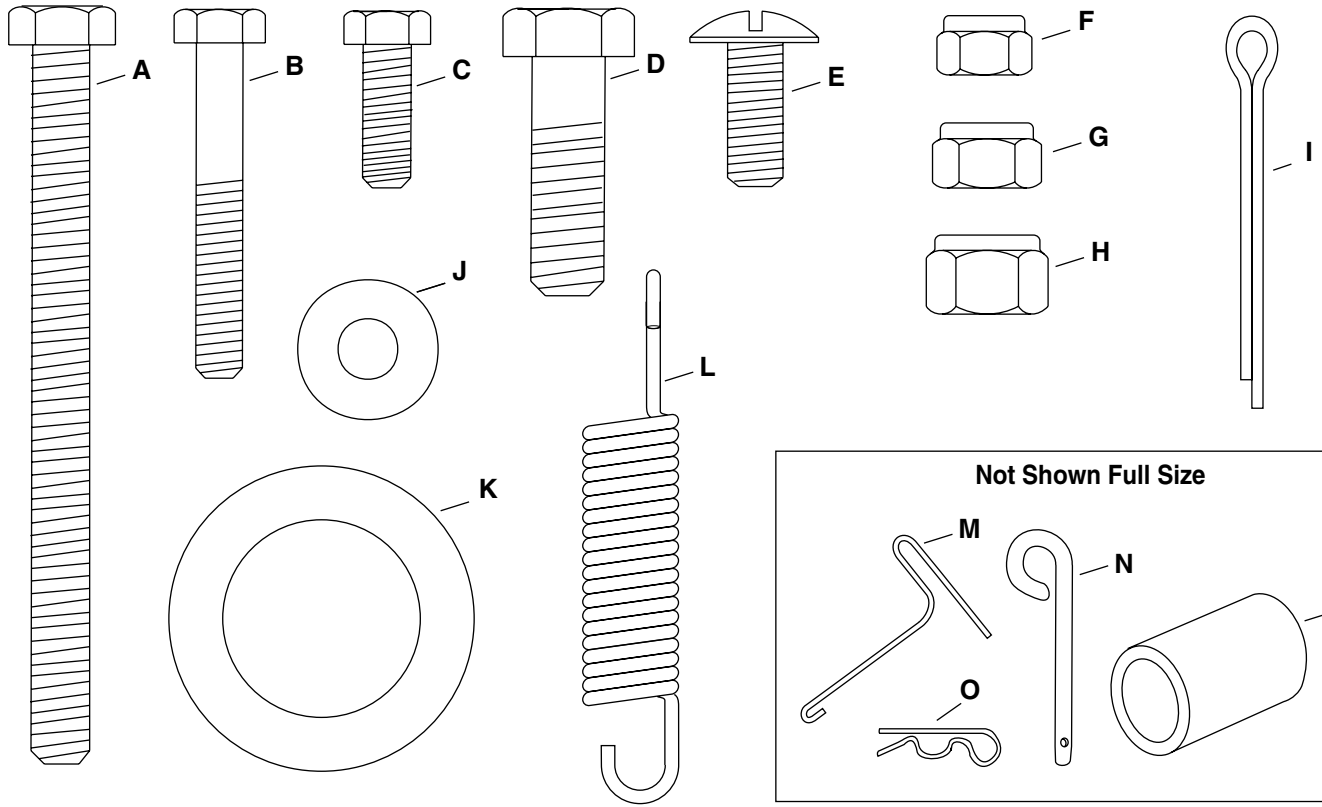

HARDWARE PACK

REF.	QTY.	DESCRIPTION	REF.	QTY.	DESCRIPTION
A	1	Hex Bolt, 5/16" x 3-3/4"	I	2	Cotter Pin, 1/8" x 1-1/2"
B	4	Hex Bolt, 1/4" x 1-3/4"	J	4	Flat Washer, 1/4"
C	4	Hex Bolt, 1/4" x 3/4"	K	4	Flat Washer, 1"
D	2	Hex Bolt, 3/8" x 1-1/4"	L	1	Extension Spring
E	8	Truss Head Bolt, 5/16" x 3/4"	M	1	Spring Puller Tool
F	8	Nylock Nut, 1/4"	N	1	Hitch Pin
G	11	Nylock Nut, 5/16"	O	1	Hair Cotter Pin
H	2	Nylock Nut, 3/8"	P	2	Spacer Tube

ASSEMBLY INSTRUCTIONS

TOOLS REQUIRED FOR ASSEMBLY

- (1) Screwdriver
- (1) Pliers
- (2) 7/16" Wrenches
- (2) 1/2" Wrench
- (2) 9/16" Wrenches

1. Remove the hardware pack and all loose parts from the carton. Be sure the carton is empty before discarding.
2. Lay out and identify all the parts and hardware as shown on pages 2 and 3.
3. Place the latch lock lever through the slot in the draw bar tongue as shown in figure 1. Assemble the 5/16" x 3-3/4" hex bolt through the tongue, the lever and two 5/16" nylock nuts (one on each side of the lever). Assemble a 5/16" nylock nut onto the end of the bolt and **tighten** so that the bolt can still rotate freely. **Tighten** the two 5/16" nylock nuts against the sides of the latch lock lever so that the lever is centered in the slot. See figure 1.

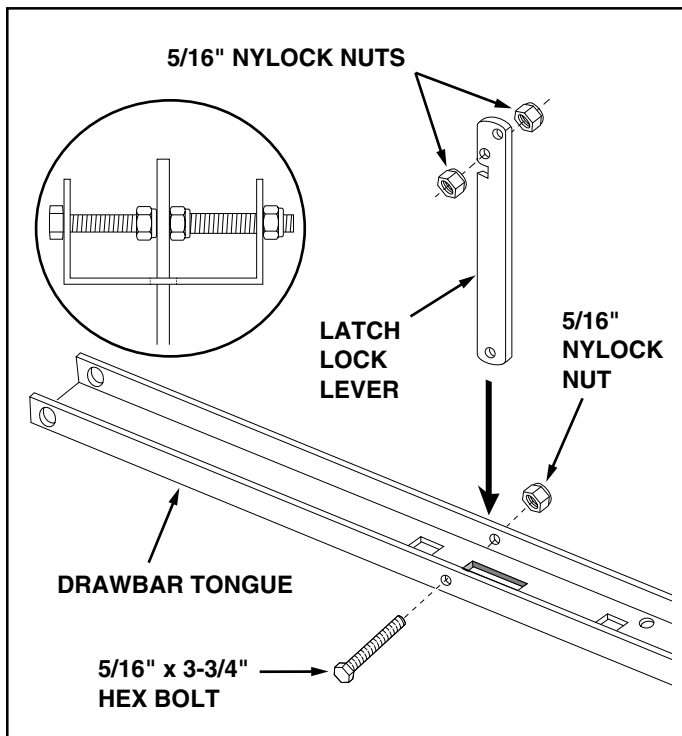

FIGURE 1

4. Hook the **short** end of the spring into the hole in the latch lock lever. Use the spring puller tool to hook the **long** end of the spring into the square hole in the tongue. The spring puller tool can be stored when finished. See figure 2.

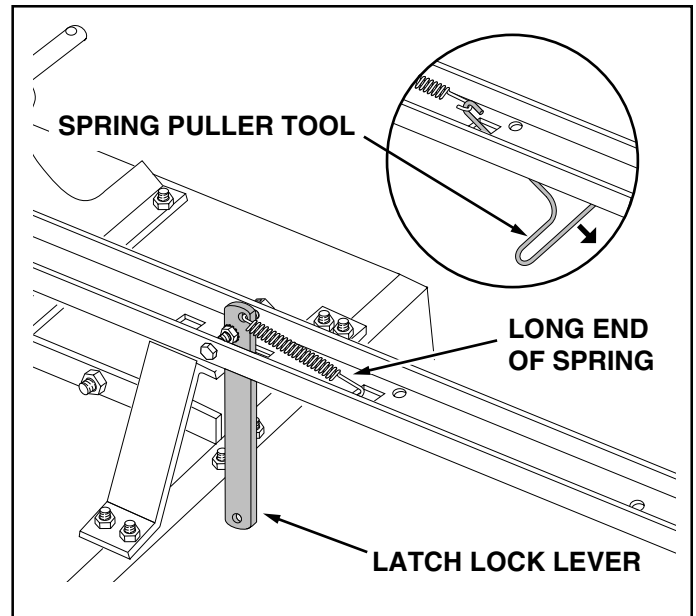

FIGURE 2

5. Assemble the end of the hitch bracket with two holes down through the slot at the front of the drawbar tongue. Fasten it to the tongue using the 3/8" x 1-1/4" hex bolt and 3/8" nylock nut. **Tighten**. See figure 3.
6. Assemble the hitch pin to the tongue and hitch bracket and secure it with the hair cotter pin. See figure 3.

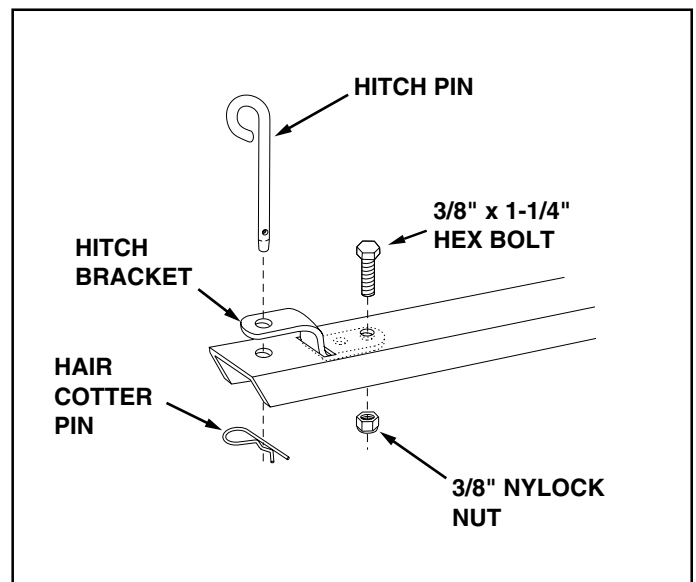

FIGURE 3

7. Assemble the axle and drawbar tongue to the wheel support, with the open side of tongue facing away from the wheel support. Fasten the axle to the wheel support using four 1/4" x 1-3/4" hex bolts and 1/4" nylock nuts. **Tighten.** See figure 4.

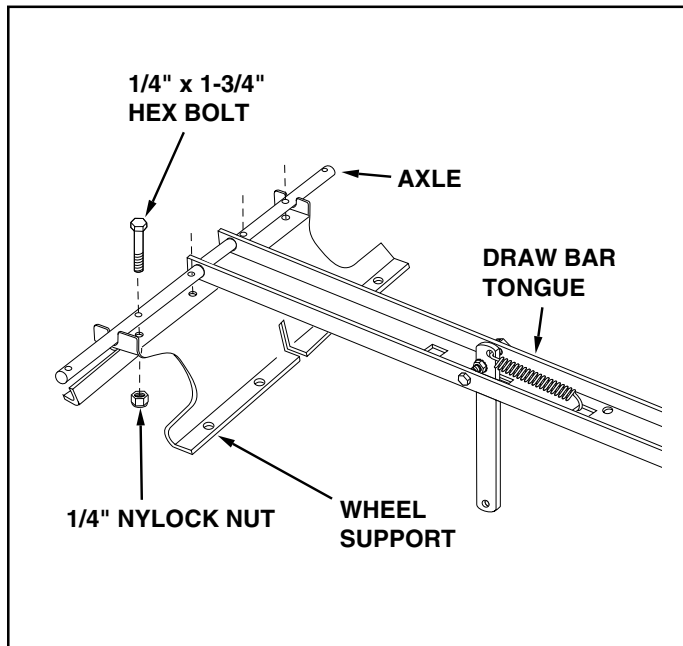

FIGURE 4

8. Assemble a spacer tube, a 1" flat washer, a wheel (valve stem facing out) and another 1" flat washer onto the axle as shown in figure 5. Insert a cotter pin through the axle, spreading the ends. Fill wheel hub with grease. Repeat on other end of axle.

IMPORTANT: Pump grease into grease fittings until it is forced out through ends of wheel hub.

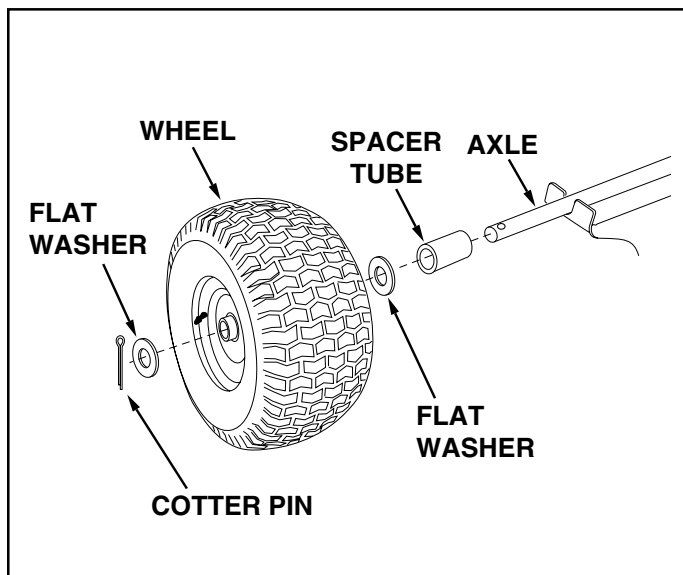

FIGURE 5

9. Assemble the latch stand plate and the latch stand bracket to the bottom of the poly tray using four 1/4" x 3/4" hex bolts, 1/4" flat washers and 1/4" nylock nuts. The aligning tab on the bottom of the latch stand bracket must be towards the rear of the cart. **Tighten.** See figure 6.

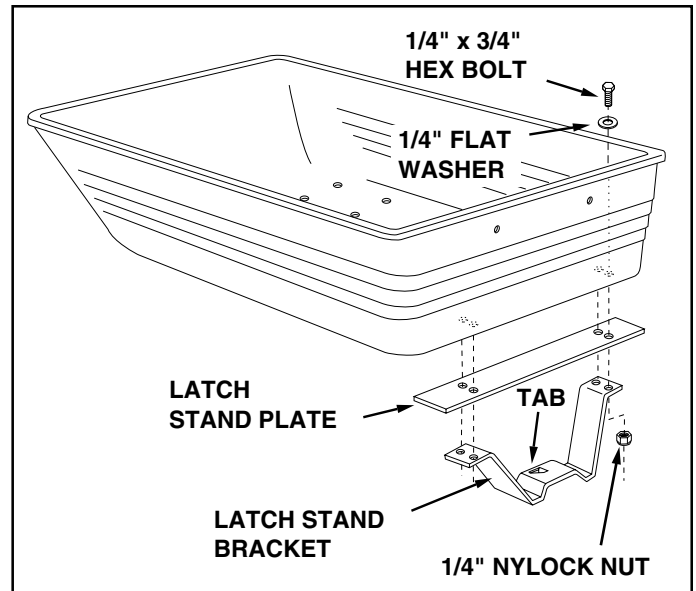

FIGURE 6

10. Place the poly tray down onto the wheel support, positioning it so that the latch stand bracket snaps under the latch lock lever. Fasten the tray to the wheel support using eight 5/16" x 3/4" truss head bolts and 5/16" nylock nuts as shown in figure 7. **Tighten.**

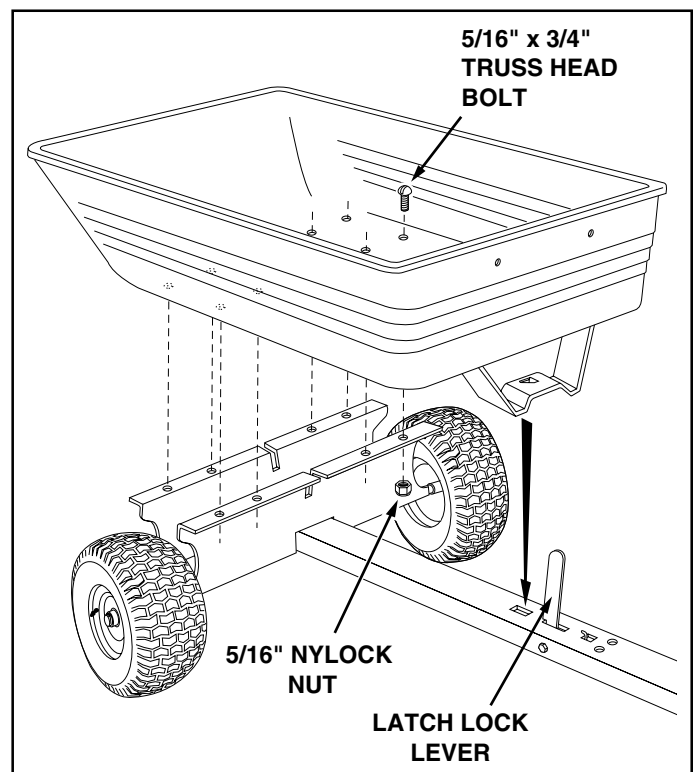

FIGURE 7

OPERATION



CAUTION: VEHICLE BRAKING AND STABILITY MAY BE AFFECTED WITH THE ADDITION OF AN ACCESSORY OR AN ATTACHMENT. BE AWARE OF CHANGING CONDITIONS ON SLOPES.

1. Refer to the vehicle owners manual for instructions on safe operation on slopes.
2. Use the slope guide provided on page 11 of this manual to determine whether slope angle is too steep for safe operation.
3. For best handling and traction, distribute the weight of the load evenly in the cart.
4. Always test to make sure your vehicle has adequate towing and braking capabilities whenever hauling a substantial amount of weight in your cart. Use extra caution when operating on slopes.



NOTE

DO NOT EXCEED WEIGHT CAPACITY OF CART

(See the specifications on this page.)

One cubic foot of dirt weighs approximately 150 lbs.

5. To dump material from the cart, release the spring latch on the tongue by pulling the latch lock lever forward, away from the cart. The cart bed will then tilt backwards to empty its contents. After emptying, pull the front of the bed down toward the cart tongue until the latch snaps into place.
6. The maximum towing speed for this cart is 20 m.p.h.



CAUTION: TO AVOID POSSIBLE INJURY, BEFORE RELEASING THE LATCH BE SURE THAT NO ONE IS NEAR THE CART.

MAINTENANCE

1. At the beginning of each season, using a light machine oil, lubricate the latch, the latch pivot bolt, and the area of the axle where the draw bar tongue pivots .
2. At the beginning of each season, grease the wheel bearings. Apply grease through the grease fitting until grease is forced out through the ends of the wheel hub.
3. Check periodically for loose bolts.
4. Keep tires filled. Do not exceed maximum tire pressure of 10 Lbs.

CART SPECIFICATIONS

Tires: 18" x 9.5" Pneumatic
Axle: 1" Dia. Steel
Capacity: Up to 650 Lbs. Max.
Approx. Sh. Wt. 100 Lbs.

NOTES

REPAIR PARTS FOR POLY CART MODEL 45-01751

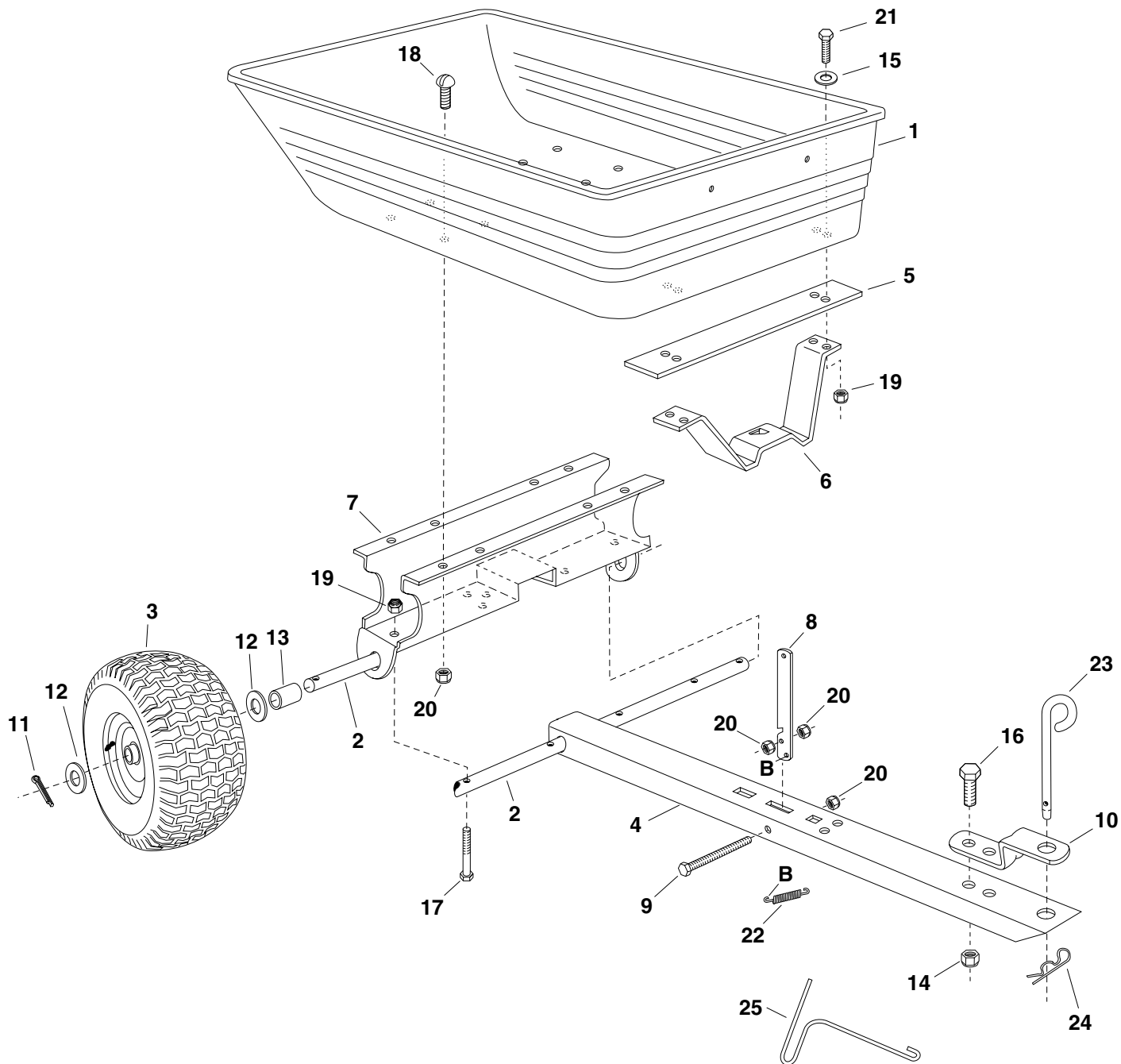

REPAIR PARTS FOR POLY CART MODEL 45-01751

REF. NO.	PART NO.	QTY.	DESCRIPTION
1	47019	1	Poly Tray
2	24528	1	Axle, 1"
3	48906	2	Wheel
4	24758	1	Draw Bar Tongue
5	24386	1	Latch Stand Plate
6	24497	1	Latch Stand Bracket
7	24527	1	Wheel Support
8	24498	1	Latch Lock Lever
9	47407	1	Hex Bolt, 5/16-18 x 3-3/4"
10	23475	1	Hitch Bracket
11	43093	2	Cotter Pin, 1/8" x 1-1/2"
12	43601	4	Washer, Flat 1.59" O.D. x 1" I.D.
13	47453	2	Spacer Tube, 3-1/8" Lg.
14	HA21362	1	Nylock Nut, 3/8-16*
15	43088	4	Flat Washer, 1/4"
16	43087	1	Hex Bolt, 3/8-16 x 1-1/4" *
17	1509-69	4	Hex Bolt, 1/4-20 x 1-3/4" *
18	43814	8	Truss Head Bolt, 5/16-18 x 3/4"
19	47189	8	Nylock Nut, 1/4-20
20	47810	11	Nylock Nut, 5/16-18
21	43012	4	Hex Bolt, 1/4-20 x 3/4" *
22	47408	1	Extension Spring
23	23353	1	Hitch Pin
24	43343	1	Hair Cotter Pin, 3/32"
25	47622	1	Spring Puller
	49171	1	Owner's Manual

* Purchase Common Hardware Locally

SpeedEPart *the fastest way to purchase parts* www.speedepart.com

SLOPE GUIDE

(Keep this sheet in a safe place for future reference.)

Use this guide to determine if a slope is safe for the operation of your tractor and cart. Refer also to the instructions in your vehicle owners manual.

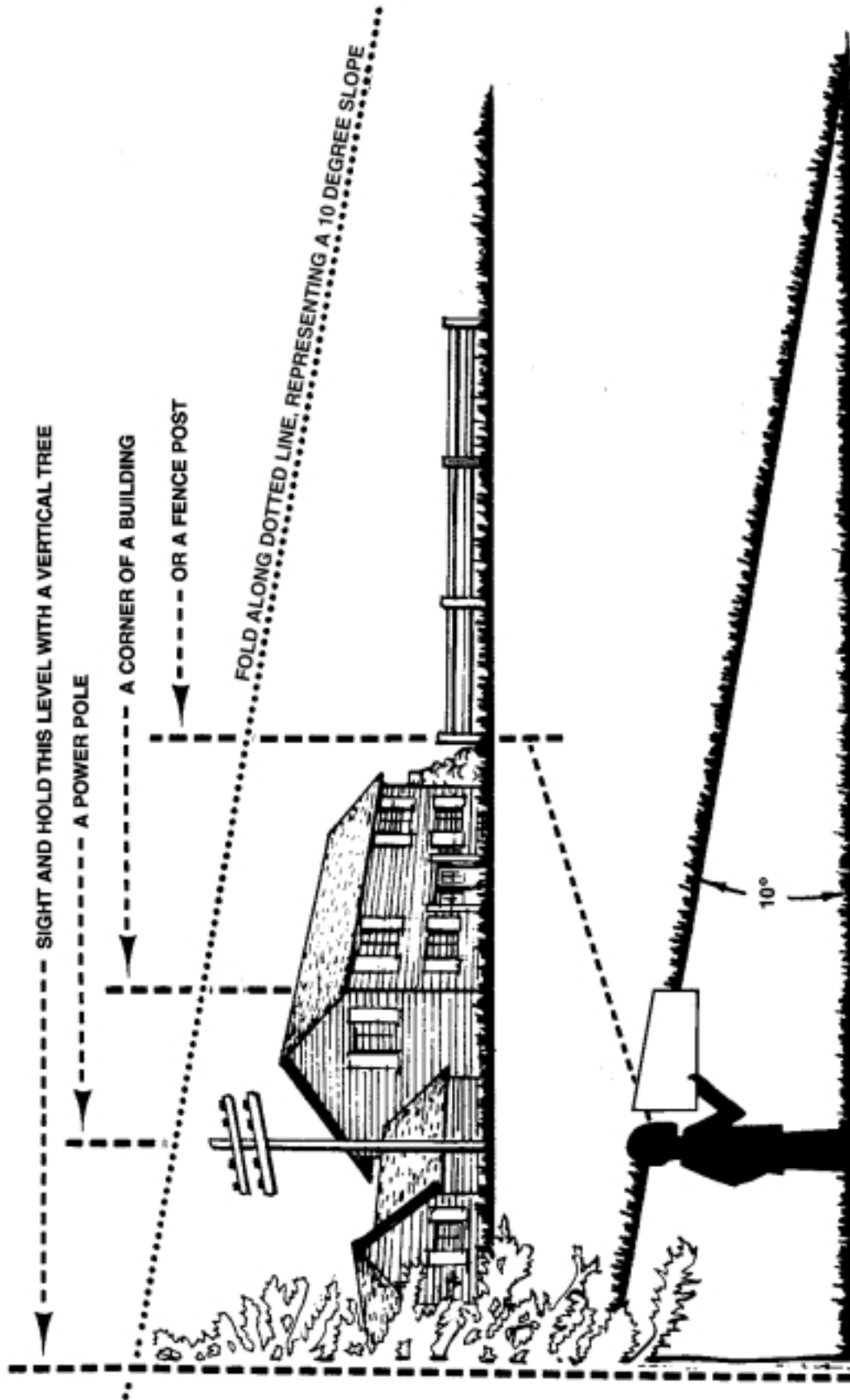

CAUTION: DO NOT OPERATE YOUR TRACTOR AND CART ON A SLOPE IN EXCESS OF 10 DEGREES. BE SURE OF YOUR TRACTOR'S TOWING AND BRAKING CAPABILITIES BEFORE OPERATING ON A SLOPE. AVOID ANY SUDDEN TURNS OR MANEUVERS WHILE ON A SLOPE.



SpeedPart *the fastest way to purchase parts* www.speedepart.com

REPAIR PARTS

Agri-Fab, Inc.
303 West Raymond
Sullivan, IL. 61951
217-728-8388
www.agri-fab.com