

# **owners manual**

**Model No.  
45-01771**

## **IMPORTANT:**

Read Rules for  
Safe Operation  
and Instructions  
Carefully

P. 5

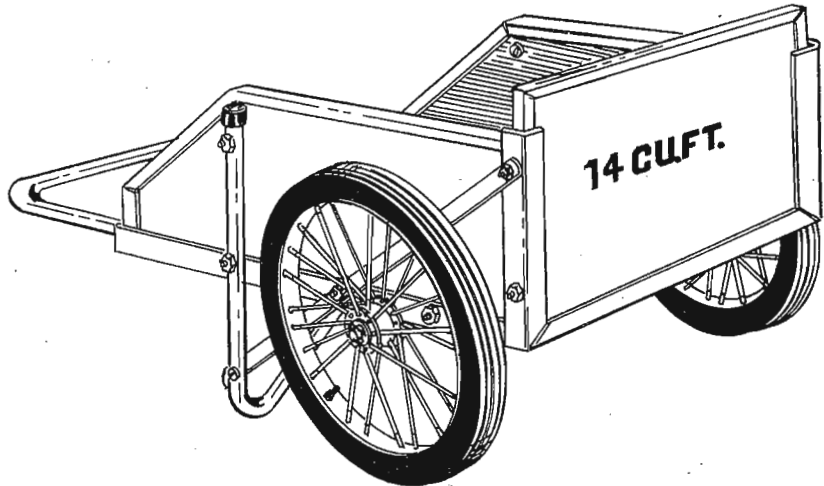

## **14 CU. FT. FARM/YARD CART**

- **Assembly**
- **Maintenance**
- **Repair Parts**

**Agri-Fab**  
INC.

• 303 WEST RAYMOND • SULLIVAN, ILLINOIS 61951

PRINTED IN U.S.A.

FORM NO. 45006  
(Rev. 11/91)

# RULES FOR SAFE OPERATION

Preventing accidents is the responsibility of every equipment operator. The following general safety precautions must be fully understood and followed by every operator.

1. Do not at anytime carry passengers in this cart. It is designed for carrying materials only and not intended to carry passengers.
2. Be careful on any grade (hill) and stay off of steep grades.
3. Use caution when loading cart to avoid tipping.
4. Avoid large holes and ditches when transporting loads.

Your Farm/Yard cart carton contains a hardware package with parts as shown in the chart below and figure 1.

Contents of Hardware Pack: (See figure 1)

REF. No.	QTY.	DESCRIPTION
A	6	Screws, 1/4-20 x 1-3/4" Long
B	4	Rubber Cap 1/4" x 3/8" Long
C	8	Screw, 1/4-20 x 1" Long
D	17	Screws, 1/4-20 x 3/4" Long
E	4	Flat Washers 25/32" x 1-1/2" O.D.
F	33	Hex Nuts 1/4-20 Thread
G	33	Flat Washers 1/4" I.D.
H	2	Cotter Pins
I	2	Tube Cap 1" x 1" Long
J	2	Screw, 1/4-20 x 1-1/4" Long

## FULL SIZE HARDWARE REFERENCE CHART

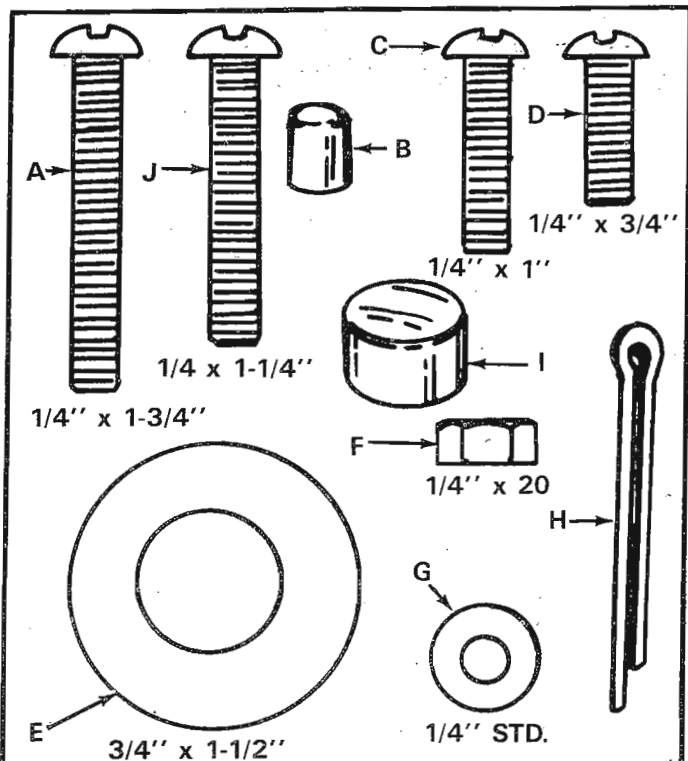

FIGURE 1.

# ASSEMBLY INSTRUCTIONS

## TOOLS REQUIRED

- (1) Screw Driver
- (1) Pair of Pliers
- (1) 7/16" Open End or Box Wrench

When assembling your cart, place the heads of all screws to the inside and hex nuts with flat washers outside.

1. Lay the front angle assembly down (flat) on floor and stand the bottom panel in position as shown in figure 2.



The bottom panel has one galvanized edge, this is the rear. The front edge has three holes. See figure 2.

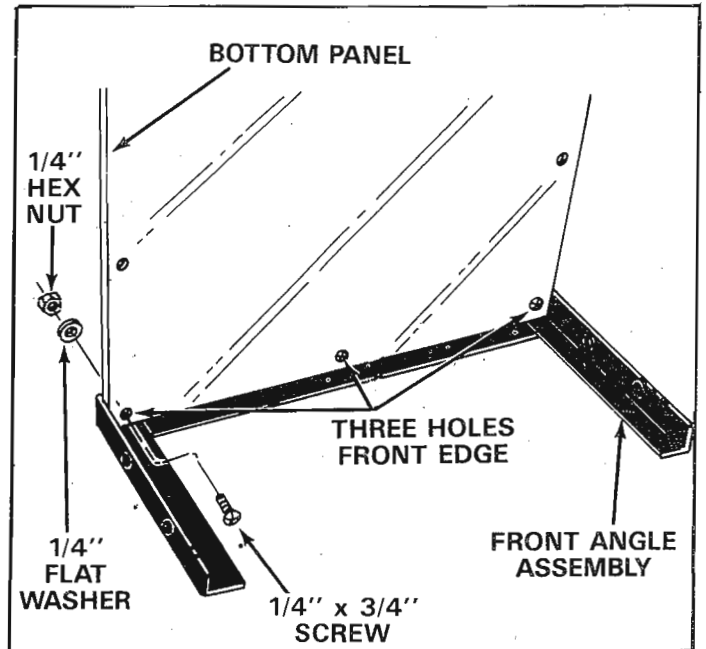

FIGURE 2.

2. Line up three holes in bottom panel with holes in front angle assembly. Start three 1/4" x 3/4" truss head screws through bottom panel, then through angle. Secure screws with flatwashers and hex nuts. See figure 2. Tighten securely.

3. Turn front angle assembly and bottom panel upside down as shown in figure 3.
4. Lay the two side angles on bottom panel so that the axle sleeves are towards the front angle assembly. See figure 3.

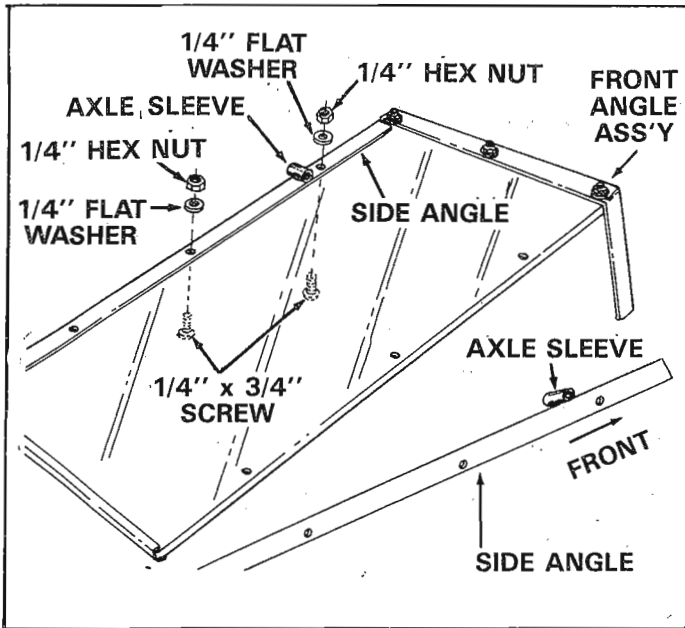

FIGURE 3

5. Secure two side assemblies to the bottom panel with four 1/4" x 3/4" truss head screws, flat-washers and hex nuts in front two holes each side only. See figure 3. Make only finger tight.
6. Insert axle through axle sleeves as shown in figure 11 on page 6. Tighten all nuts securely.
7. Stand cart on its front end with front angle assembly on the floor. Place four large 1-1/2" dia. flatwashers (used on wheel axle) on the inside of front angle assembly. See figure 4.



These washers act as shims and are just for assembly purposes. You will remove them later.

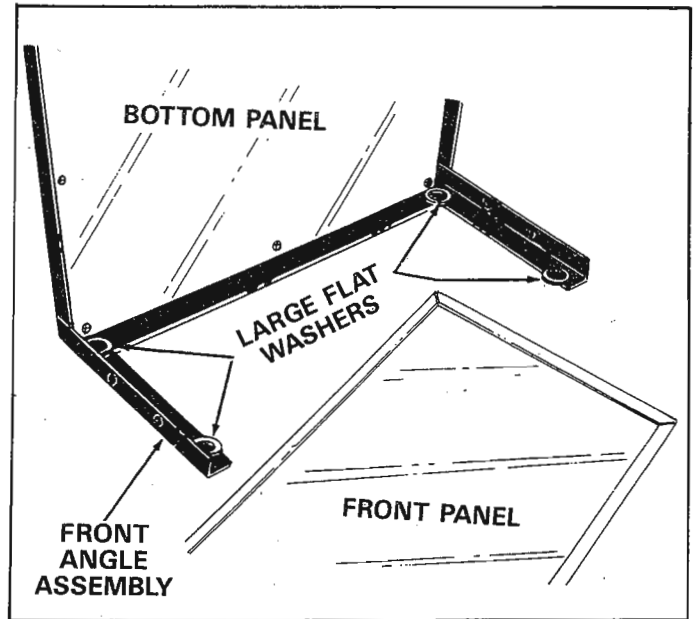

FIGURE 4

8. Lay the front panel on top of the four large washers and in the front angle assembly. See figure 5.

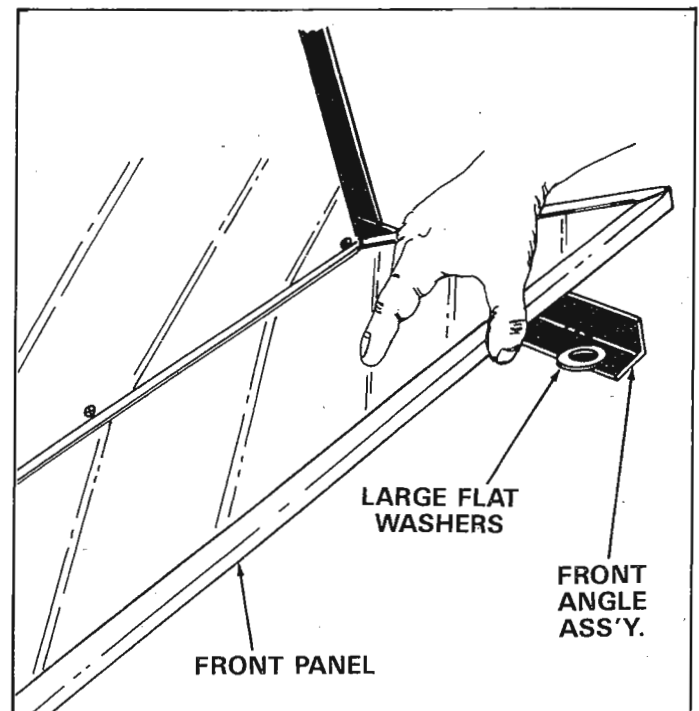

FIGURE 5

- Place one side panel in position, against side angle and down on top of front panel. Start one 1/4" x 1" truss head screw through the **second hole** in side panel, support strap and side angle. Secure with hex nut. See figure 6. **Make only finger tight as this time.**

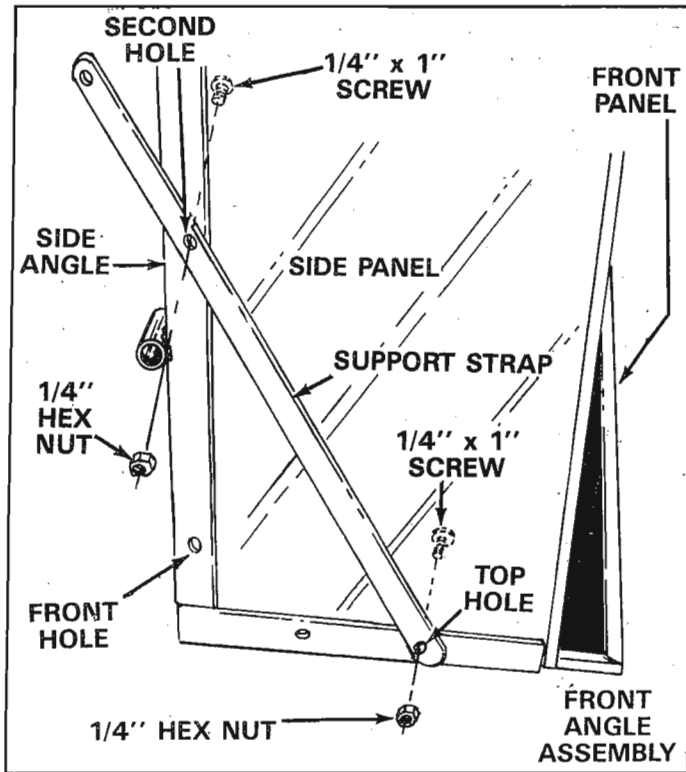

FIGURE 6

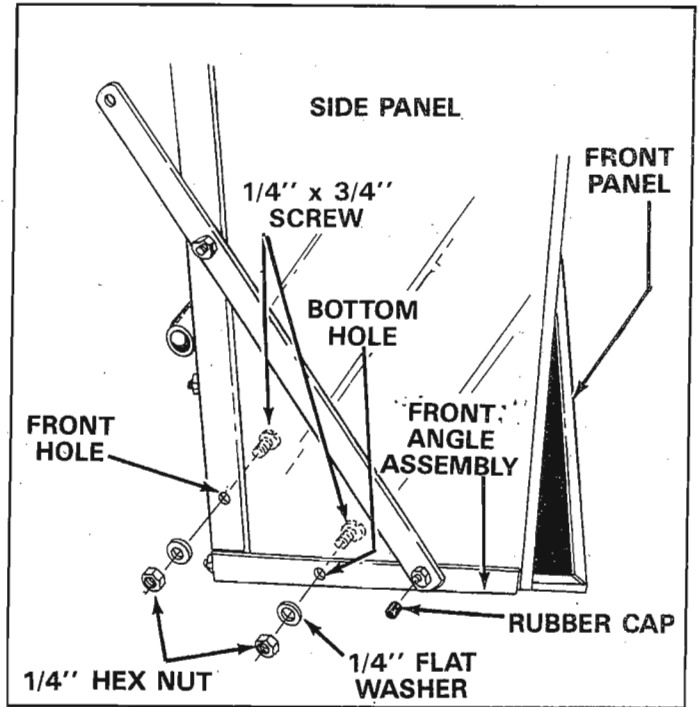

FIGURE 7

- Remove the front panel, by sliding it out, and remove the four large washers you used for shims. See figure 8.

- Assemble one 1/4" x 1" truss head screw through top hole in side panel, support strap and front angle assembly, then remove hex nut from screw assembled in step 9, next place support strap over these two screws and secure with hex nuts. See figure 6. **Make only finger tight at this time.**

- Repeat steps 9 and 10 for the other side panel.

- Assemble one 1/4" x 3/4" truss head screw through bottom hole in side panel and front angle assembly and another 1/4" x 3/4" truss head screw through front hole in side panel and side angle. Secure with flat washers and hex nuts. See figures 6 and 7. **Make only finger tight at this time.**

- Repeat step 12 for the other side panel.

- Now tighten all nuts and screws securely.** Install rubber cap on top screws installed in step 10 and step 11 as shown in figure 7.

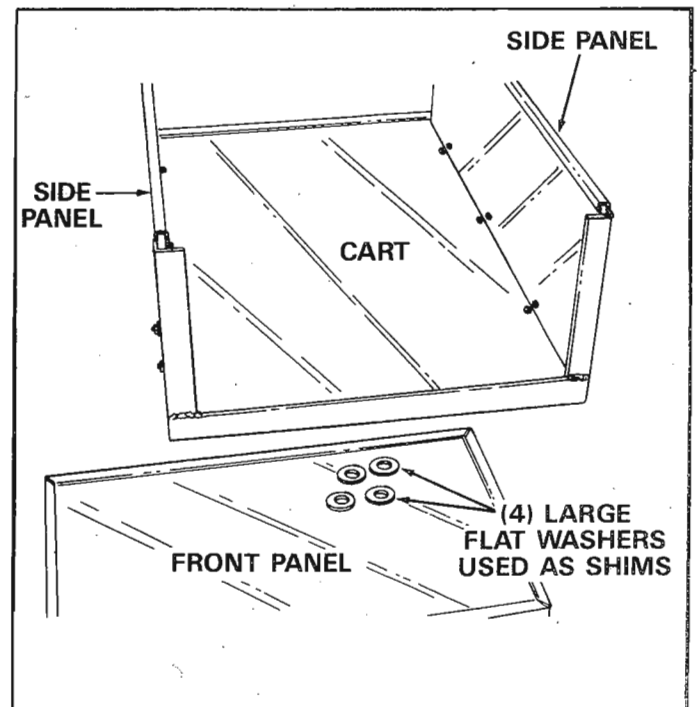

FIGURE 8

- Turn the cart upside down. Place the handle tube on bottom of cart as shown in figure 9. Place the four clamps over handle tube **with the longer leg of clamp to the outside edge of cart.** See figure 9.



The length of the handle tube can be adjusted by sliding in or out before tightening the four clamps. See figure 9.

- Secure the four clamps over handle tube with four 1/4" x 3/4" screws, four 1/4" x 1" screws and eight 1/4" flat washers and eight 1/4" hex nuts, make only finger tight until all eight screws are in place. Then tighten securely.

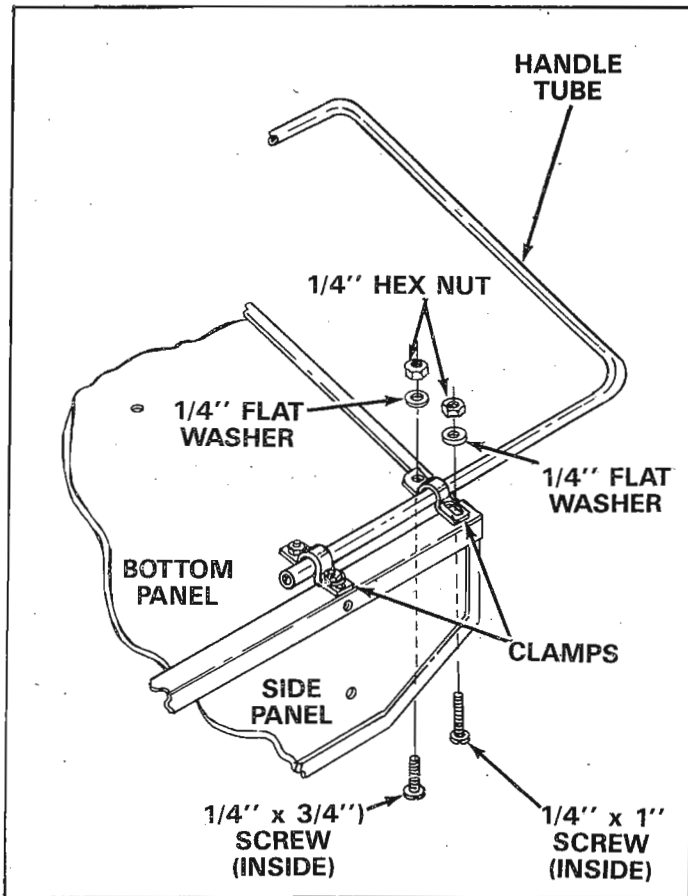

FIGURE 9.



Place tube caps on ends of "W" leg. See figure 10.

- With cart still upside down, assemble the leg to bottom and side of cart. Line up holes in center of "W" leg with two holes in bottom. Secure with two 1/4" x 1-3/4" screws, inserted from inside of cart, fasten with 1/4 flat washers and 1/4 hex nuts. See figure 10. Do not tighten at this time.

- Assemble the leg to each of the side panels with two 1/4 x 1-3/4" screws, inserted from inside of cart, fasten with 1/4 flat washers and hex nuts. See figure 10. Assemble 1/4" x 3/4" screws in back hole of both side angles and fasten with 1/4" flat washers and hex nuts.

- Assemble the leg to each of the support straps with two 1/4 x 1-1/4 screws and secure with 1/4" flat washers and hex nuts. See figure 10.

- Now tighten all screws and nuts securely. Install rubber caps on 1/4 x 1-3/4" screws as shown in figure 10.

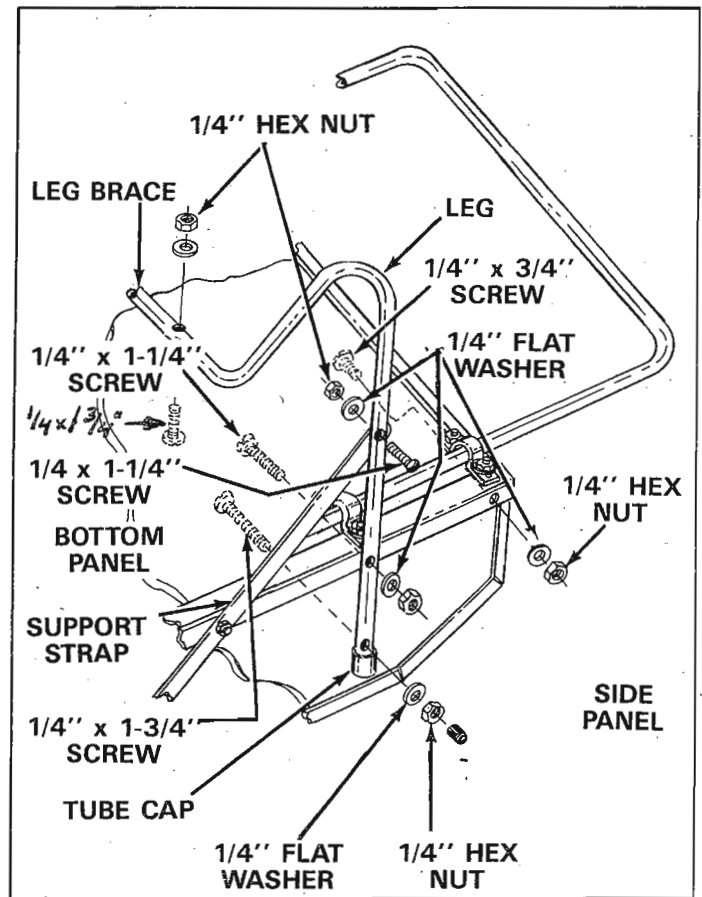

FIGURE 10.

22. Place one 1-1/2" dia. flat washer on axle, then wheel, one more large flat washer and secure with cotter pin. See figure 11 and note below. Repeat step for other wheel.

**NOTE**

If cotter pin can not be assembled through hole in the axle ends, remove one washer from inside, next to sleeve.

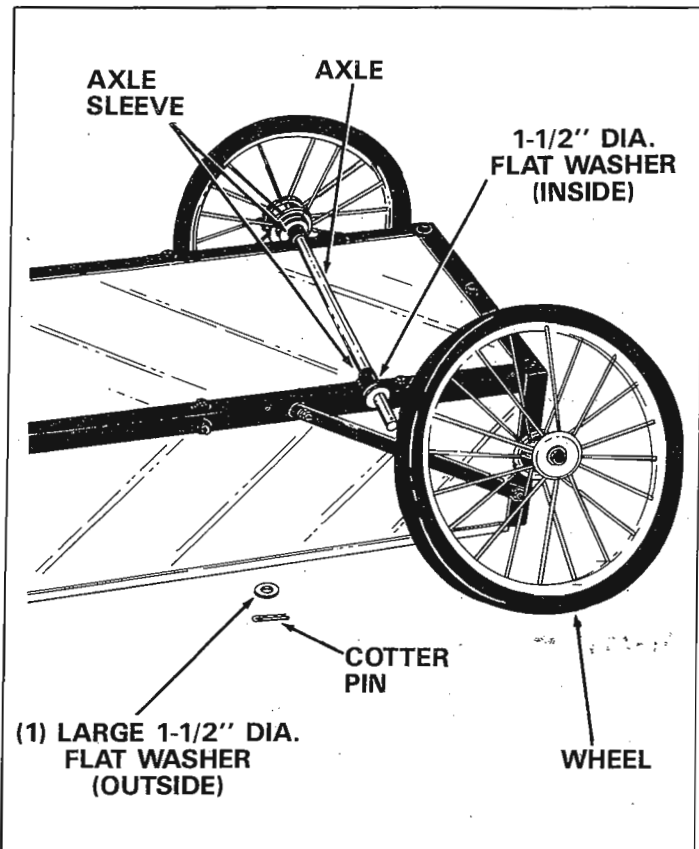

FIGURE 11.

23. Turn cart right side up, so that it rests on its wheels.
24. Place front panel in guides to complete assembly.
25. Your cart is now ready to use.

## MAINTENANCE

1. Grease or oil wheel bearings occasionally. Use automotive wheel bearing type grease or 20 weight oil.
2. Periodically retighten all screws, especially after heavy use. **Do not exceed load capacity rating of 400 lbs.**
3. Clean cart thoroughly after each use.
4. Store indoors during severe weather.
5. Apply light coat of varnish to all wood surfaces annually.
6. Use glossy black enamel spray paint to touch-up scratched or worn paint surfaces.

**RECOMMENDED TIRE PRESSURE 25-30 PSI.**

**MAXIMUM TIRE PRESSURE 30 PSI**

# MODEL 45-01771 14 CU. FT. FARM/YARD CART

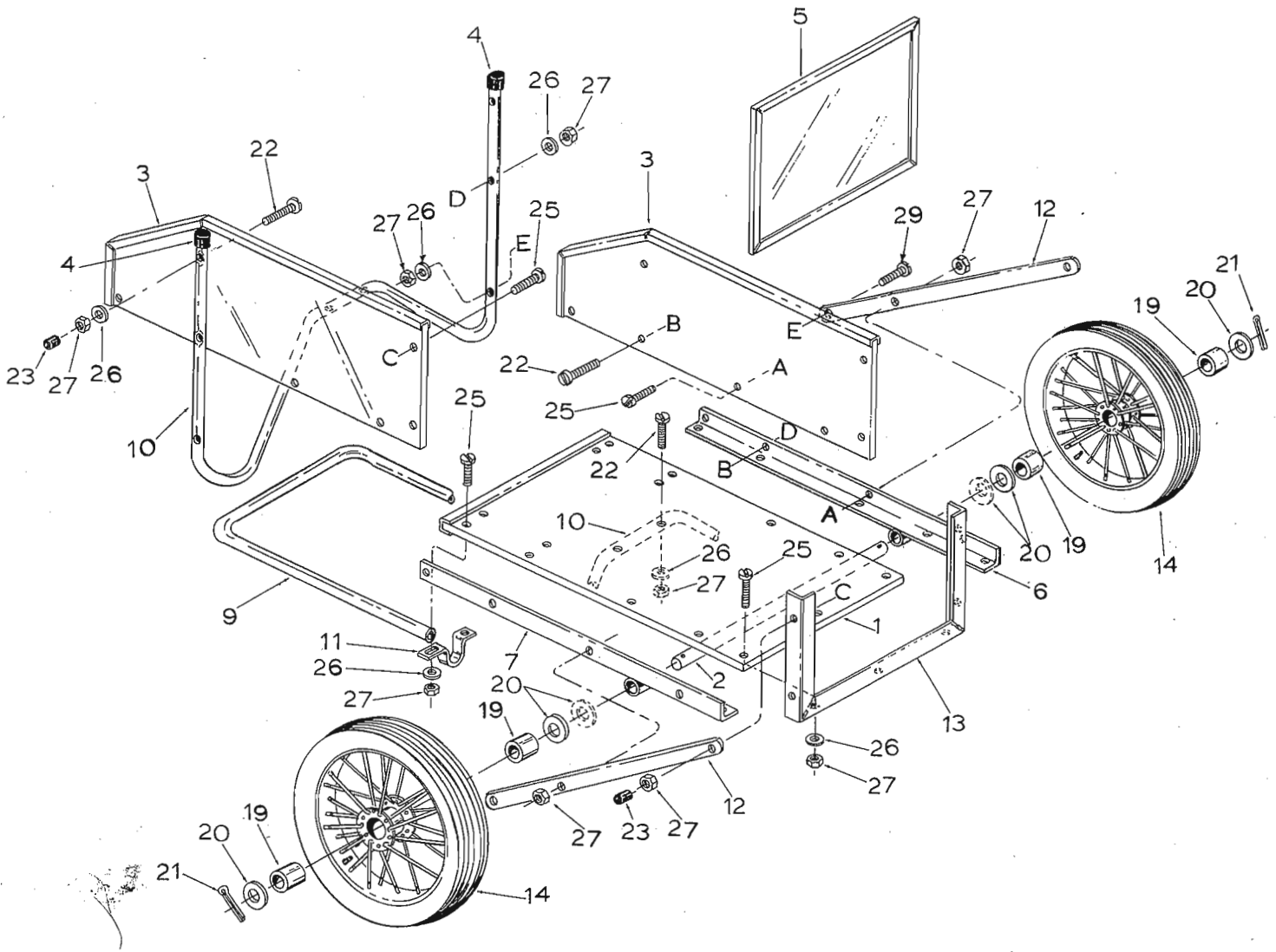

## PARTS LIST FOR MODEL NO. 45-01771 FARM/YARD CART

REF. NO.	PART NO.	QTY.	DESCRIPTION	REF. NO.	PART NO.	QTY.	DESCRIPTION
1	44027	1	Bottom Panel	20	43949	4	Fl.-Wash. 25/32" x 1-1/2" x 3/32"
2	23594	1	Axle, Wheel	21	43010	2	Cotter Pin, 1/8" x 1-1/4"*
3	44028	2	Side Panel	22	44022	6	Truss Head Screw 1/4-20 x 1-3/4" Lg.*
4	44021	2	Tube Caps	23	44538	4	Cap, Rubber 1/4 x 3/8" Lg.
5	44029	1	Front Panel	25	44023	17	Truss Head Screw 1/4-20 x 3/4" Lg.*
6	62537	1	Side Angle Ass'y.-L.H.	26	43088	33	Flat Washer 1/4" Std.*
7	62536	1	Side Angle Ass'y.-R.H.	27	43178	33	Hex Nut 1/4-20 Thd.*
9	44031	1	Handle Tube	28	44259	8	Truss Head Screw 1/4-20 x 1" Lg.*
10	44522	1	Leg Tube	29	44020	2	Truss Head Screw 1/4-20 x 1-1/4" Long*
11	44033	4	Clamp, Tube		45006	1	Owner's Manual
12	23882	2	Support Strap				
13	62535	1	Front Angle Ass'y.				
14	43945	2	Wheel/Complete w/Brg. 26"				
19	44016	4	Ball Bearings 3/4" I.D.				

\*Purchase Common Hardware Locally.

**REPAIR PARTS**  
303 West Raymond Street  
Sullivan, Illinois 61951  
(217)728-8388