

owners manual

Model No.'s

45-0101
45-0171
45-0184
190-653-100
190-368-100
190-425-100

IMPORTANT:

Read Rules for
Safe Operation
and Instructions
Carefully

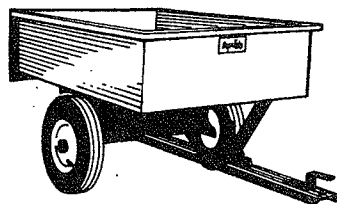

45-0101
190-653-100
10 CU. FT. (STD.)

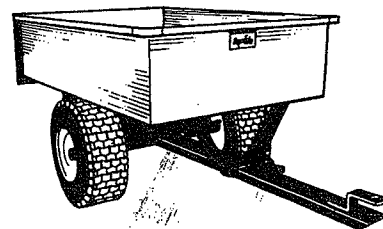

45-0171
190-368-100
10 CU. FT. (H.D.)

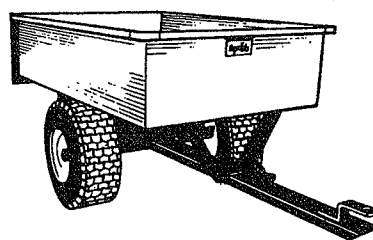

45-0184
190-425-100
17.0 CU. FT. (H.D.)

UTILITY CARTS

(SEE SPECIFICATIONS PAGE 7)

- Assembly
- Operating
- Maintenance
- Repair Parts



• 303 WEST RAYMOND • SULLIVAN, ILLINOIS 61951

PRINTED IN U.S.A.

FORM NO. 43812
(Rev. 10/90)

ASSEMBLY INSTRUCTIONS

Contents of Hardware Pack:
(See figure 1)

REF.	DESCRIPTION	MODEL NO. AND QUANTITY		
		45-0101	45-0171	45-0184
A	Pin, Cotter 1/8 x 1" Long	2	0	0
B	Pin, Cotter 1/8" x 1-1/2" Long	0	2	2
C	Washer, Flat 25/32 I.D.	4	0	0
D	Washer, Flat 1.032 I.D.	0	4	4
E	Hub Cap	2	2	2
F	Hex Bolt 1/4 x 1/2" Long	23	23	25
G	Hex Bolt 1/4 x 5/8" Long	6	6	6
H	Hex Bolt 1/4 x 3/4" Long	6	6	6
I	Hex Bolt 1/4 x 1-1/2" Long	2	0	0
J	Hex Bolt 1/4 x 1-3/4" Long	0	2	2
K	Lock Washer 1/4" I.D.	37	37	39
L	Hex Nut 1/4" Thread	37	37	39
M	Lock Washer 3/8" I.D.	2	2	2
N	Hex Nut 3/8" Thread	2	2	2
O	Slotted Truss Head Bolt 5/16" x 3/4" Long	14	14	14
P	Lockwasher 5/16" I.D.	14	14	14
Q	Hex Nut 5/16" Thread	14	14	14
R	Hex Bolt 3/8" x 1" Long	2	2	2

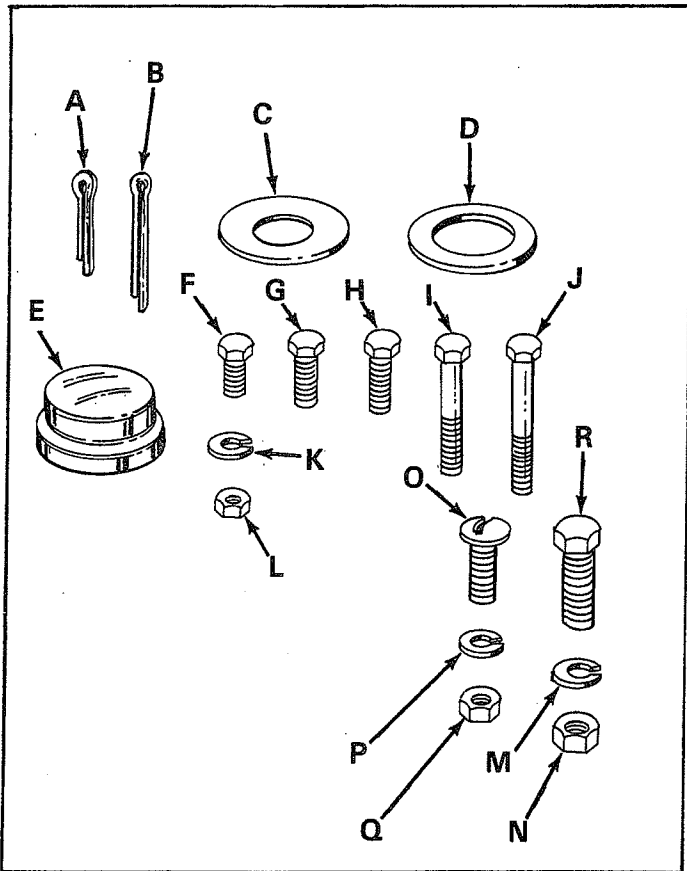

FIGURE 1.

IDENTIFICATION OF LOOSE PARTS (See figure 2)

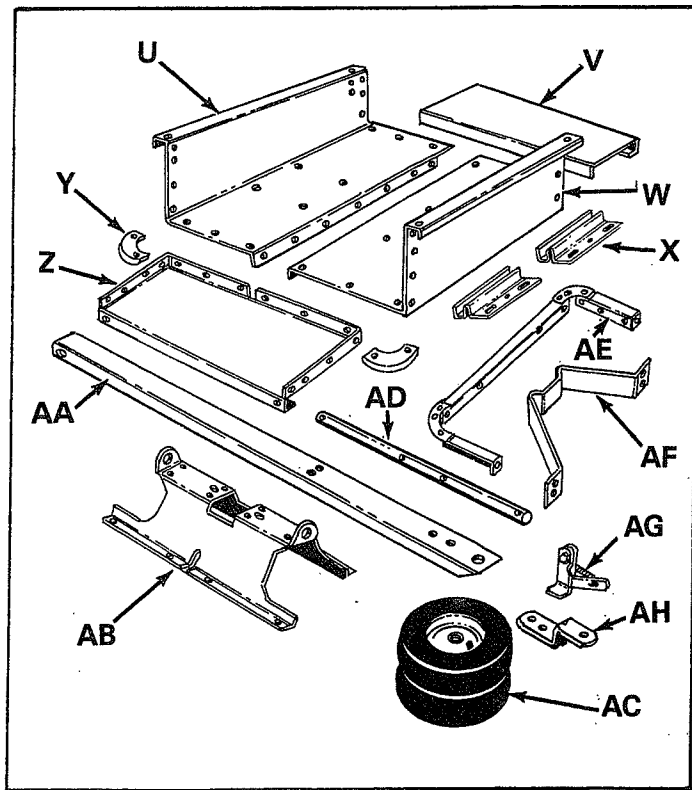

FIGURE 2.

LOOSE PARTS (See figure 2)

- U Cart Body - Right Hand
- V Tailgate
- W Cart Body - Left Hand
- X Tailgate Guides
- Y Corner Caps
- Z Front Panel
- AA Draw Bar Tongue
- AB Wheel Support
- AC Wheels
- AD Axle
- AE Tailgate Reinforcement Bracket
- AF Latch Stand Bracket
- AG Latch Lock Sub-Assembly
- AH Hitch Bracket

1. Remove the hardware pack and all loose parts from the carton. Be sure carton is empty before discarding.
2. Layout all the parts as shown in figure 2.
3. Position cart body halves (U and W) upright as shown in figure 3. **NOTE:** Large diameter holes to the top.

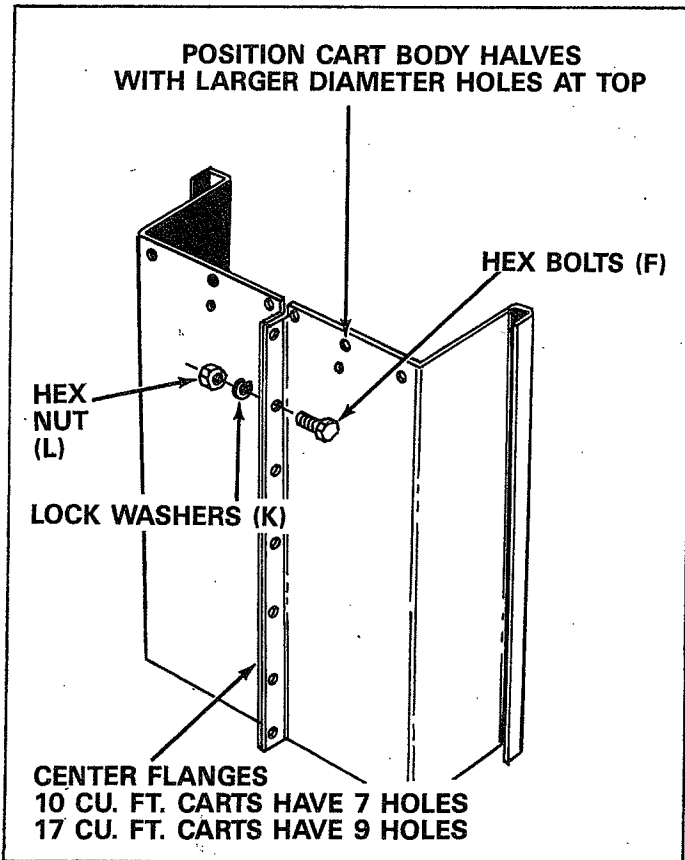

FIGURE 3

4. Start bolts (F), lock washers (K) and hex nuts (L) through flanges, only make **finger tight** until all 7 or 9 bolts are in place. See figure 3 and note below.



Bolts are tightened later in step 15, page 5.

5. Position the wheel support (AB) in place on the bottom of cart. See figure 4.
6. Assemble wheel support to cart with eight slotted head screws (O), lock washers (P) and hex nuts (Q). See figure 4. Heads of screws go to the inside of cart and should be tightened at this time.

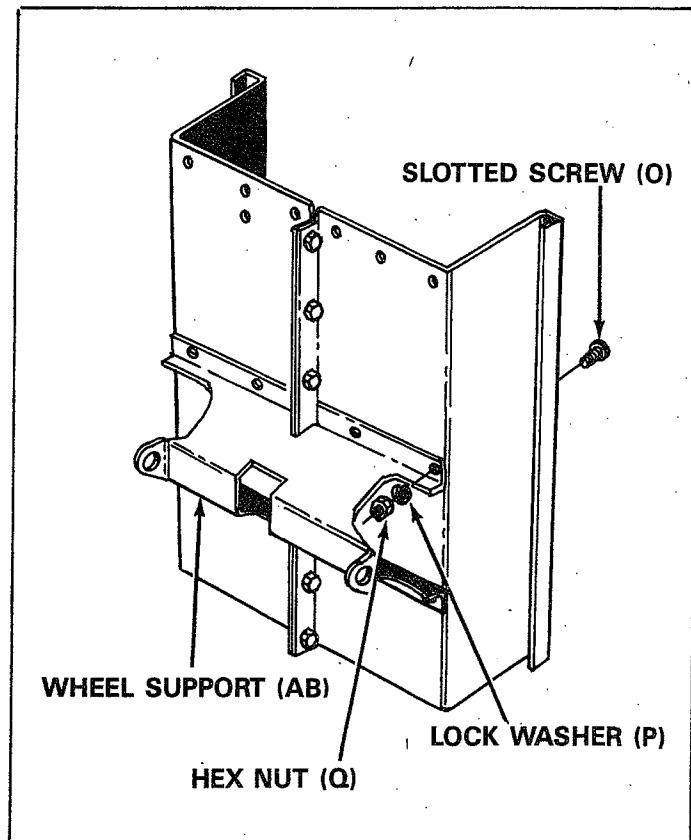
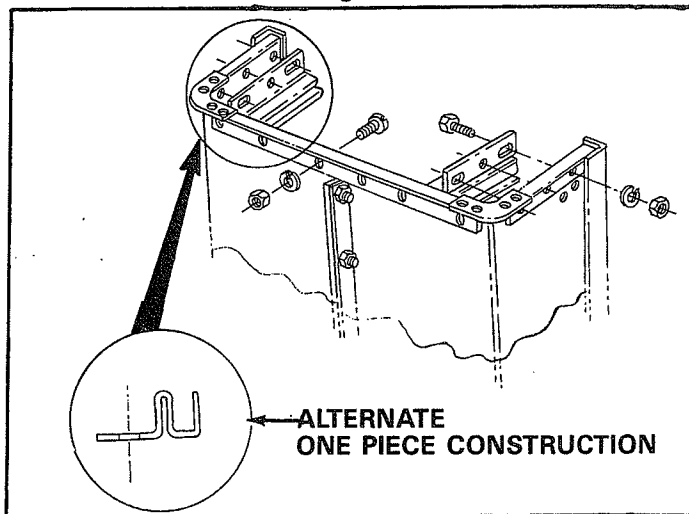
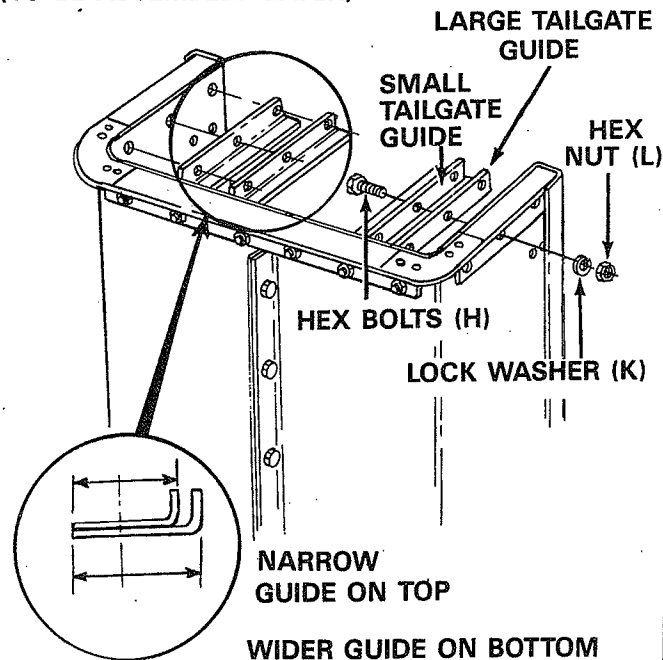

FIGURE 4

7. Position the tailgate reinforcement bracket (AE) over end of cart. See figure 5.
8. Start slotted screws (O) through bottom of cart (heads of screws to the inside of cart) and reinforcement bracket. Secure finger tight with hex nuts (Q) and lock washers (P). See figure 5.
9. Position the tailgate guides (X) so that the holes line up with reinforcement bracket and cart body. Refer to tailgate guide detail in figure 5.
10. Secure tailgate guides with six hex bolts (H) lock washers (K) and hex nuts (L). See figure 5. Tighten bolts assembled in steps 7, 8 and 9 at this time. Do not tighten others.



**LEAVE OUT BOLTS
IN TOP FLANGE HOLES
(TO BE ASSEMBLED LATER)**



TAILGATE GUIDE DETAIL

FIGURE 5

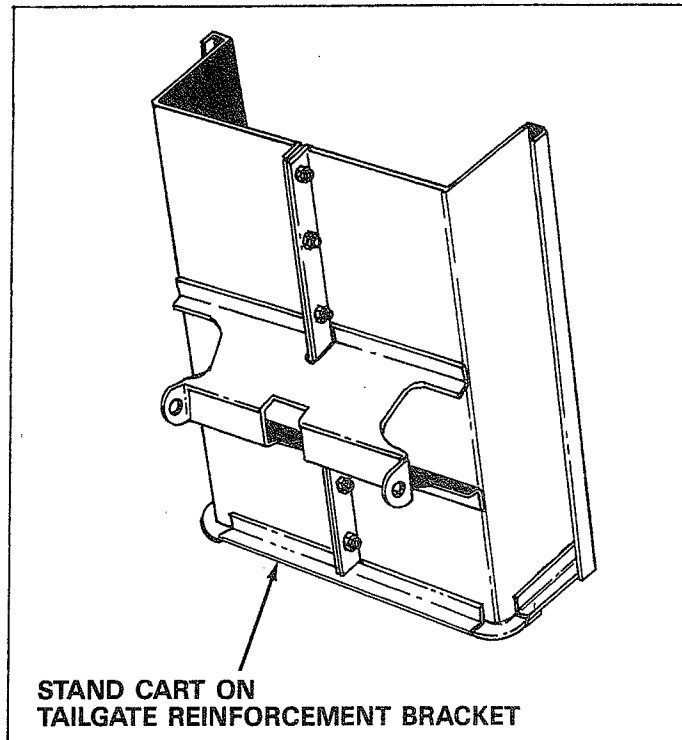

FIGURE 6

11. Reverse the cart position and stand on tailgate reinforcement bracket and proceed with assembly steps 12 through 19. See figure 6.
12. Assemble front panel to open end of cart body, using 1/4" x 1/2" hex bolts (F), lock washers (K) and hex nuts (L). Bolt heads to inside of cart. Leave out (2) bolts for latch stand bracket. See figure 7.

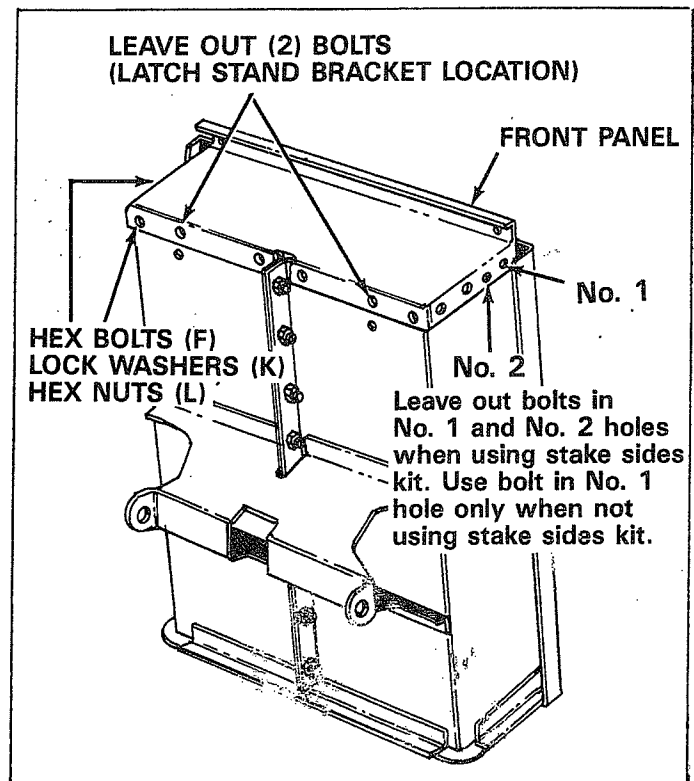

FIGURE 7

NOTE

Do Not assemble bolts in No. 1 of No. 2 holes when using optional stakesides kit (each side). See figure 7.

13. Assemble latch stand bracket using four 1/4" x 5/8" hex bolts (G), lock washers (K) and hex nuts (L). See figure 8.

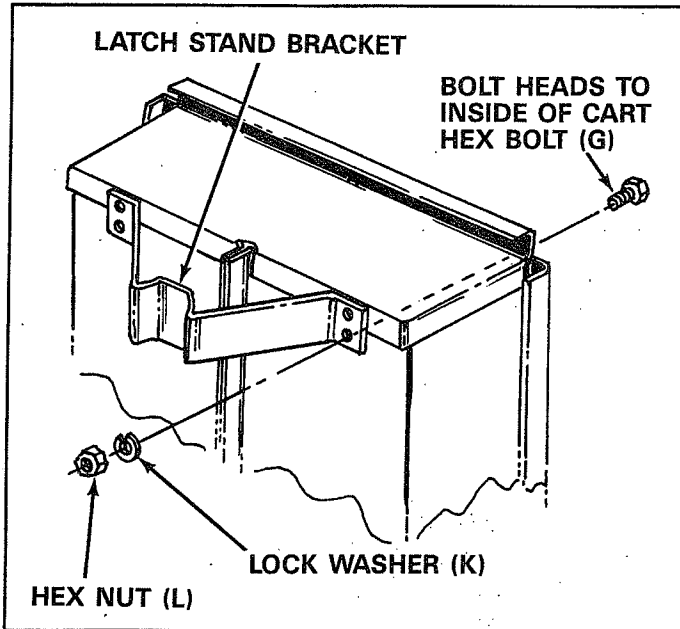

FIGURE 8

14. Assemble two front top corner caps and two bolts in top flanges through tailgate reinforcement bracket using 1/4" x 1/2" hex bolts (F), lock washers (K) and hex nuts (L). See figure 9. Tighten all bolts.
15. Tighten all bolts assembled in step 4 through 14, lower cart assembly to rest on top flanges, with axle support up. See figures 10 and 12.

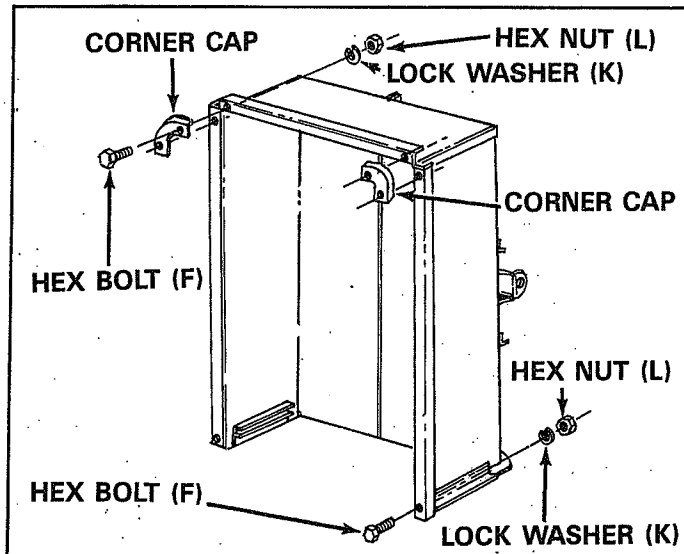

FIGURE 9

16. Assemble latch lock subassembly to drawbar tongue using 1/4" x 5/8" long hex bolt (G), lock washers (K) and hex nuts (L). See figure 10.

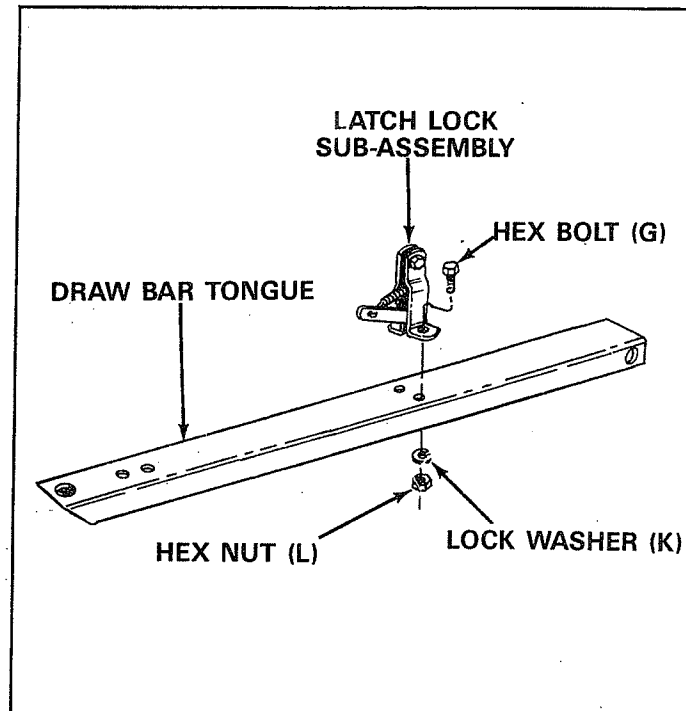

FIGURE 10

17. Assemble hitch bracket to drawbar tongue, using 3/8" x 1" long hex bolts (R), lock washers (M) and hex nuts (N). See figure 11.

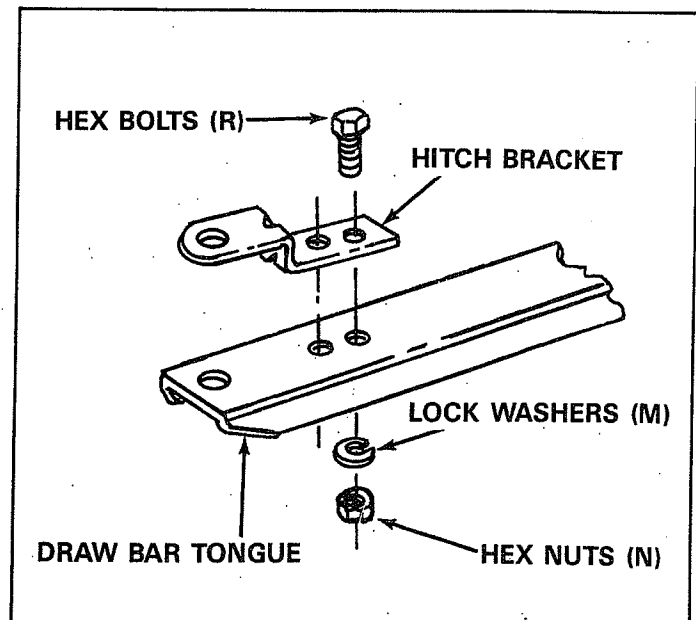

FIGURE 11

- Assemble axle and draw bar tongue to wheel support keeping open side of tongue facing up, make sure that latch lock snaps over latch stand. Secure axle to wheel support or axle brackets, using 1/4" x 1-3/4" long hex bolts (J), lock washers (K) and hex nuts (L). See figure 12.

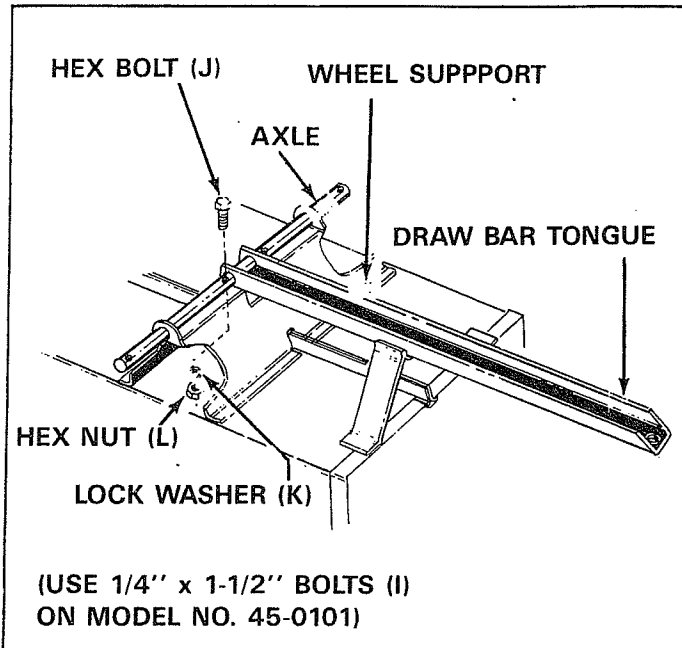

FIGURE 12

MODELS 45-0171, AND 45-0184: STEP 19 ONLY.

- Assemble large diameter flat washer (D), wheel, another flat washer (D), cotter key (B) and hub cap (E) to each axle end.



Position valve stem to outside when installing wheels on axle. See figure 13.

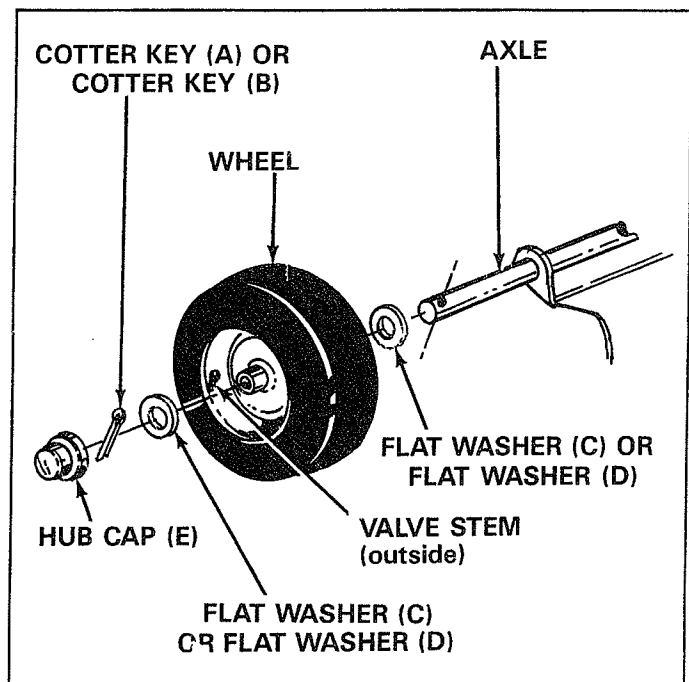

FIGURE 13

MODEL 45-0101: STEP 20 ONLY.

- Assemble wheels as described in step 19, using flat washers (C), cotter keys (A) and hub caps (E). See figure 13.
- Turn cart assembly over to rest on wheels. This completes the cart assembly. Be sure to read safety rules and operating instructions before using your new utility cart.

GENERAL SAFETY PRECAUTIONS



Preventing accidents is the responsibility of every equipment operator. The following general safety precautions must be fully understood and followed by every operator.

1. Do not at anytime carry passengers in this cart. It is designed for carrying materials only and not intended to carry passengers.
2. Do not tow this utility cart on a public thoroughfare at any time. The operator is risking injury from passing vehicles. Most local ordinances prohibit operating a cart and tractor such as this on a public thoroughfare.
3. When towing cart do not drive too close to a creek or ditch and be alert for holes and other hazards. The above could cause you to lose control of the cart and tractor.
4. Be careful on any grade (hill) and stay off of steep grades.
5. Maximum towing speed - 10 M.P.H.

OPERATION

To dump material from the trailer box, remove the tailgate by lifting it straight up and out from between the guides. Release the spring latch by pulling the latch handle forward, away from the trailer box.



CAUTION

To avoid possible injury, be sure that no one is near the trailer before releasing latch.

A cord may be attached to the spring latch handle for easy release by the operator while in the tractor's seat. The trailer box will tilt backward to empty its contents. After unloading, pull the front of the box down toward the trailer tongue until the latch snaps in place. Replace tailgate if desired.



NOTE

For best handling, do not load trailer too heavily behind center of axle.

MAINTENANCE

At the beginning of each season, lubricate the latch, latch pivot bolt, and the axle where the hitch tongue pivots, with a light machine oil.

1. Grease or oil wheel bearings occasionally. Use automotive wheel bearing type grease or 20 weight oil.
2. Recommended tire pressure is 12-14 Lbs.

Weight limit-See specifications for each model. One cubic foot of dirt weights approximately 150 lbs.

Do Not exceed cart weight capacity.

SPECIFICATIONS; MODEL 45-0101-10 Cu. Ft. (Std.)

Bed: 18 Ga. Steel Construction, 32½" W; 49"L; 12" H; Approx. Inside Dim.-30" x 46½"
Tailgate: Removable with Reinforced Guides
Tires: 16.00" x 4.00" Pneumatic, Rib Tread
Axle: ¾" Dia. Steel
Capacity: Up to 750 Lbs. Max.
Finish: Baked Enamel—Body: Red; Black
Approx. Sh. Wt.: 114 Lbs.
Carton Size: 14½" H x 18¾" W x 49½" L (7.79 Cu. Ft.)
Optional Accessory: (.67 Cu. Ft.)
Model No. 45-0102-11" High Wood Stake Sides Kit

SPECIFICATIONS; MODEL 45-0171-10 Cu. Ft. (H.D.)

Bed: 16 Ga. Steel Construction—32½"W; 49"L; 12" H; Approx. Inside Dim.—30" x 46½"
Tailgate: Removable with Reinforced Guides
Tires: 16.00" x 6.50" Pneumatic, Turf Tread
Axle: 1.0" Dia. Steel
Capacity: Up to 1200 Lbs. Max.
Finish: Baked Enamel—Body; Ivory; Black
Approx. Sh. Wt.: 145 Lbs.
Carton Size: 18½" H x 18¾"W x 49½"L (9.94 Cu. Ft.)
Optional Accessory: (.67 Cu. Ft.)
Model No. 45-0102-11" High Wood Stake Sides Kit

SPECIFICATIONS; MODEL 45-0184-17.0 Cu. Ft. (H.D.)

Bed: 16 Ga. Steel Construction—36½"W; 61"L; 14" H; Approx. Inside Dim.—34" x 58½"
Tailgate: Removable with Reinforced Guides
Tires: 16.00" x 6.50" Pneumatic, Turf Tread
Axle: 1.0" Dia. Steel
Capacity: Up to 1500 Lbs. Max.
Finish: Baked Enamel—Body; Ivory; Black
Approx. Sh. Wt.: 180 Lbs.
Carton Size: 16½"Hx20½"Wx60½"L (11.84 Cu. Ft.)

REPAIR PARTS FOR: UTILITY CARTS MODEL No.'s 45-0101, 45-0171, AND 45-0184

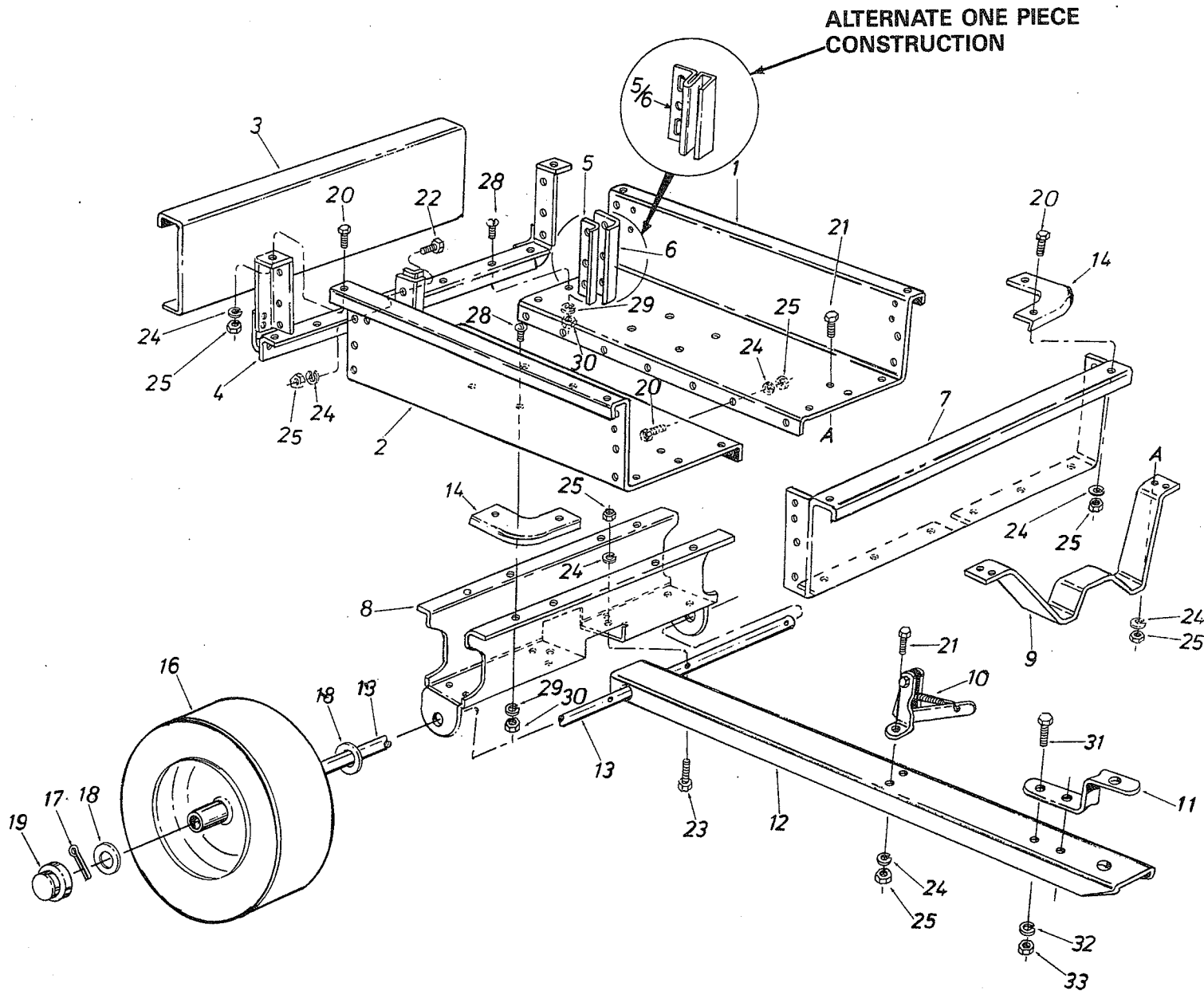

PARTS LIST FOR UTILITY CARTS

REF. NO.	DESCRIPTION	PART NO.	MODEL NO. AND QUANTITY		
			45-0101	45-0171	45-0184
1	Cart Body — L.H.	23513	1	----	----
	Cart Body — L.H.	23515	----	1	----
	Cart Body — L.H.	23517	----	----	1
2	Cart Body — R.H.	23514	1	----	----
	Cart Body — R.H.	23516	----	1	----
	Cart Body — R.H.	23518	----	----	1
3	Tailgate	23502	1	----	----
	Tailgate	23503	----	1	----
	Tailgate	23504	----	----	1
4	Sub-Ass'y., Rear Angle	62458	1	1	----
	Sub-Ass'y., Rear Angle	62457	----	----	1
5	Guide, Tailgate — Inside	23547	2	2	----
	Guide, Tailgate — Inside	23549	----	----	2
5/6	Guide, Tailgate — One Piece	23767	2	2	----
6	Guide, Tailgate — Outside	23486	2	2	----
	Guide, Tailgate — Outside	23548	----	----	2
7	Front Panel	23492	1	----	----
	Front Panel	23493	----	1	----
	Front Panel	23490	----	----	1
8	Wheel Support	23506	1	----	----
	Wheel Support	23507	----	1	----
	Wheel Support	23487	----	----	1
9	Latch Stand Bracket	23095	1	----	----
	Latch Stand Bracket	23297	----	1	1
10	Ass'y. Latch Lock	62455	1	1	1
11	Hitch Bracket	23014	1	1	1
12	Draw Bar Tongue	23505	1	----	----
	Draw Bar Tongue	23482	----	1	----
	Draw Bar Tongue	23481	----	----	1
13	Wheel Axle 3/4" Dia.	23026	1	----	----
	Wheel Axle 1" Dia.	23299	----	1	----
	Wheel Axle 1" Dia.	23488	----	----	1
14	Cap, Front Corner	23484	2	2	2
16	Wheel, 4.30 x 3.75	43008	2	----	----
	Wheel, 16/6.50 x 8.00	43594	----	2	2
17	Cotter Pin 1/8" Dia. x 1" Lg.	43010	2	----	----
	Cotter Pin 1/8" Dia. x 1-1/2" Lg.	43093	----	2	2
18	Washer, Flat 25/32" I.D.	43009	4	----	----
	Washer, Flat 1.032" I.D.	43601	----	4	4
19	Hub Cap	43014	2	2	2
20	Hex Bolt 1/4" x 1/2" Lg.	43175	23	23	25
21	Hex Bolt 1/4" x 5/8" Lg.	43866	6	6	6
22	Hex Bolt 1/4" x 3/4" Lg.	43012	6	6	6
23	Hex Bolt 1/4" x 1-1/2" Lg.	43648	2	----	----
	Hex Bolt 1/4" x 1-3/4" Lg.	1509-69	----	2	2
24	Lock Washer 1/4" I.D.	43177	37	37	39
25	Hex Nut 1/4" Thread	43178	37	37	39
28	Slotted Truss Head Bolt 5/16" x 3/4" Lg.	43814	14	14	14
29	Lock Washer 5/16" I.D.	43086	14	14	14
30	Hex Nut 5/16" Thread	43083	14	14	14
31	Hex Bolt 3/8" x 1" Lg.	43001	2	2	2
32	Lock Washer 3/8" I.D.	43003	2	2	2
33	Hex Nut 3/8" Thread	43015	2	2	2
	Owner's Manual	43812	1	1	1