



# OWNERS MANUAL

**Model No.  
45-02641**

**CAUTION:**  
Read Rules for  
Safe Operation  
and Instructions  
Carefully

- Assembly
- Operation
- Maintenance
- Parts

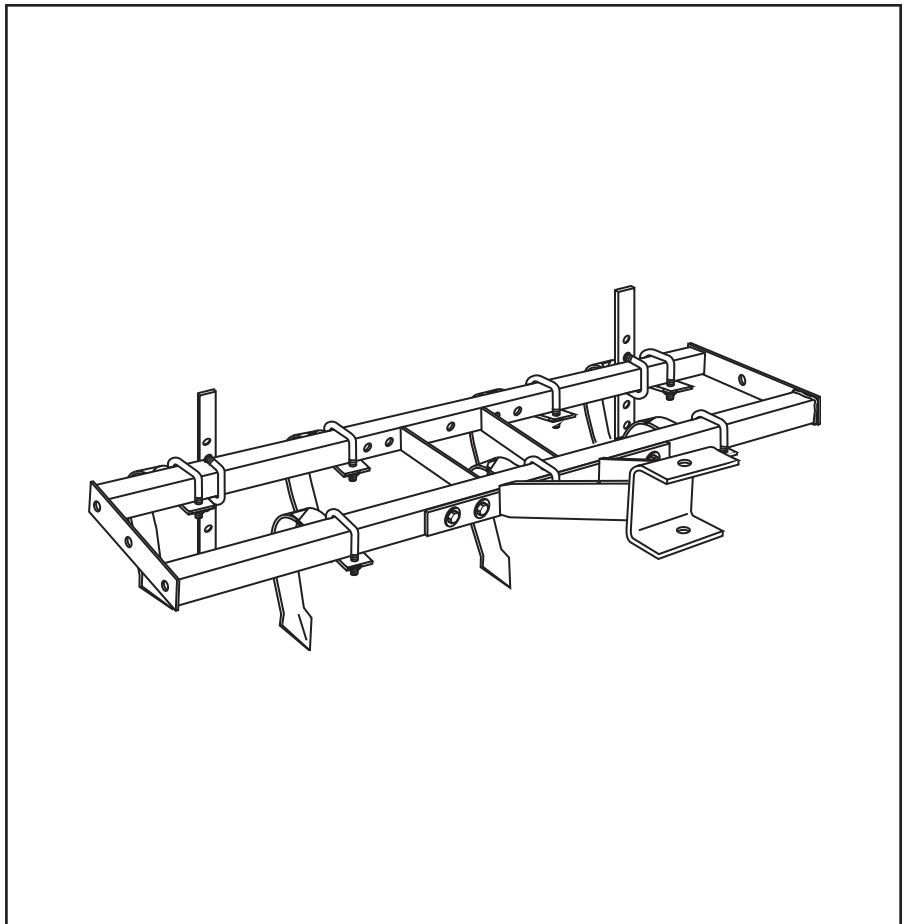

## ROW CROP CULTIVATOR (SLEEVE HITCH)

## SAFETY RULES

Any power equipment can cause injury if operated improperly or if the user does not understand how to operate the equipment. Exercise caution at all times when using power equipment.

1. Read this owners manual and your vehicle and sleeve hitch owners manuals before using this equipment.
2. Do not allow children to operate vehicle or cultivator.
3. Do not allow adults to operate vehicle or cultivator without proper instructions.
4. Do not allow anyone to ride on the cultivator.
5. Before lowering and operating the cultivator, be sure no one is near the area of operation.
6. Lower cultivator when leaving vehicle unattended.
7. Vehicle braking and stability may be affected with the attachment of this equipment. Drive slowly with cultivator in transport position. **Stay off of steep slopes.**
8. Stop and inspect for damage after striking an object. Repair any damage before continuing operation.
9. Keep all nuts and bolts tight and be sure that the equipment is in safe operating condition.
10. Lock tractor lift handle in down position when attaching or removing cultivator from sleeve hitch.



Look for this symbol to point out important safety precautions. It means — **Attention!!**  
**Become alert!!** Your safety is involved.

## ASSEMBLY INSTRUCTIONS

### TOOLS REQUIRED FOR ASSEMBLY

(2) 9/16" Wrenches

See the illustration on page 3 and the full size hardware chart on the back page.

1. Attach the hitch assembly to the frame using five 3/8" x 2-1/2" hex bolts, ten 3/8" flat washers and five 3/8" nylock nuts. **Tighten.**
2. Assemble seven cultivator tangs to the frame tubes using seven U-bolts with fourteen 3/8" nylock nuts. The alignment of rear tangs should be offset from front tangs. **Tighten.**

**NOTE:** The arrangement and the number of tangs can vary as long as the balance of the cultivator is maintained.

3. Assemble the depth gauge bars to the rear of the frame using two U-bolts with four 3/8" nylock nuts. Attach each bar using the set of holes on the bar that will provide the desired depth of tang penetration. **Tighten.**

**NOTE:** For effective depth control do not position a depth gauge bar directly behind a front tang.

## ATTACHING CULTIVATOR TO TRACTOR



**CAUTION:** Lock tractor lift handle in down position when attaching or removing cultivator from sleeve hitch.

Refer to your sleeve hitch owners manual.

1. Attach the cultivator to the sleeve hitch on your tractor using the sleeve hitch pin.
2. Tighten the two stabilizer bolts and jam nuts to eliminate looseness in the hookup.
3. Adjust the sleeve hitch so that the cultivator is free to go below ground level but can still be raised an adequate distance above ground for transport.
4. The stabilizer bolts and jam nuts should be loosened before removing the cultivator from the sleeve hitch.

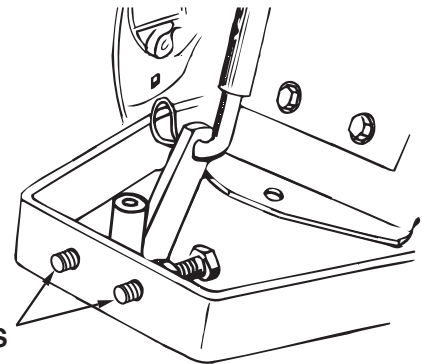

STABILIZER BOLTS

TRACTOR SLEEVE HITCH

## OPERATION

The cultivator may be used for breaking up compacted soil, for working loose soil and for cultivating between crop rows. For improved traction use wheel weights and/or tire chains.

1. Drive at a slow speed when cultivating soil.
2. Adjust the positions or remove cultivator tangs as needed for working between rows.
3. Adjust working depth of tangs by raising or lowering the depth gauge bars. Select the appropriate set of adjusting holes for conditions.
4. Up to 100 lbs. of concrete blocks or other weight may be strapped or tied to the cultivator frame to improve penetration. The cultivator should be attached to the tractor's sleeve hitch (in down position) before adding weight.
5. Do not back up when cultivator is engaged in soil.

## MAINTENANCE/STORAGE

1. Check for loose bolts after each use.
2. Clean the tangs and lightly oil any exposed metal.
3. Remove all dirt and rust and touch up with paint before storing.
4. Store inside a dry area.

# REPAIR PARTS FOR MODEL 45-02641 - ROW CROP CULTIVATOR

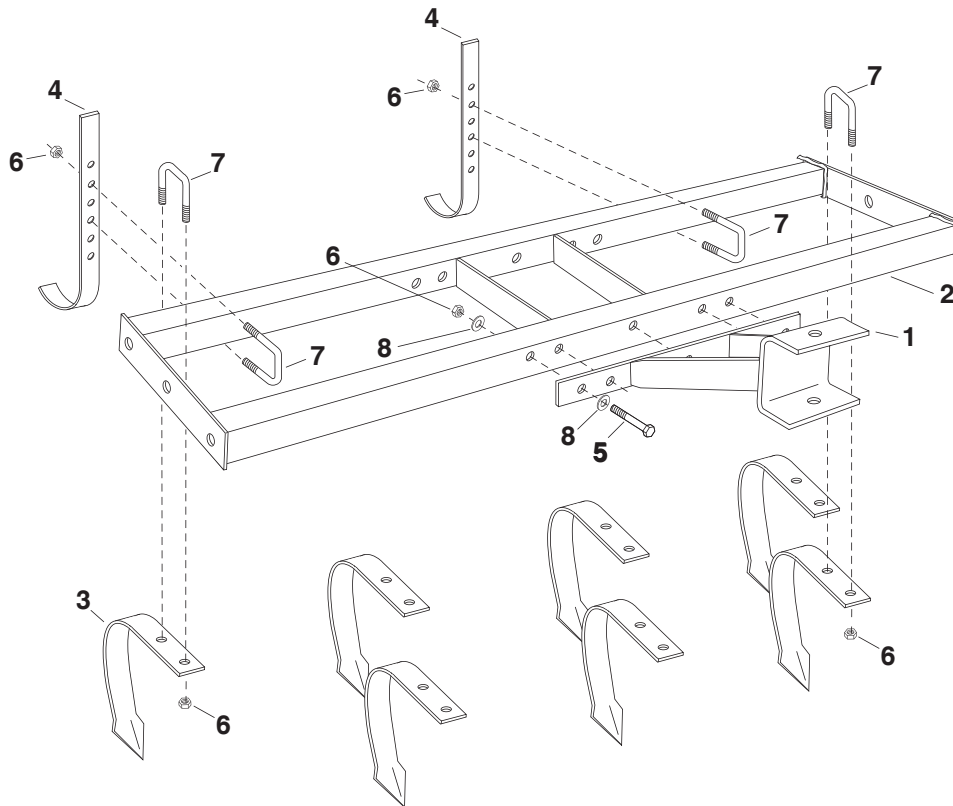

REF. NO.	PART NO.	QTY.	DESCRIPTION
1	63656	1	Hitch Ass'y.
2	64279	1	Frame Assembly
3	43022	7	Cultivator Tang
4	24238	2	Depth Gauge Bar
5	43432	5	Hex Bolt, 3/8-16 x 2-1/2" Lg.
6	HA21362	23	Nylock Nut, 3/8-16 Thread
7	46853	9	U-Bolt, 3/8-16 Thread
8	43070	10	Flat Washer, 3/8" Std. Wrt.
	48284	1	Owners Manual

# FULL SIZE HARDWARE CHART

