

OWNERS MANUAL

Model No's.

45-0294 (40")

45-0295 (48")

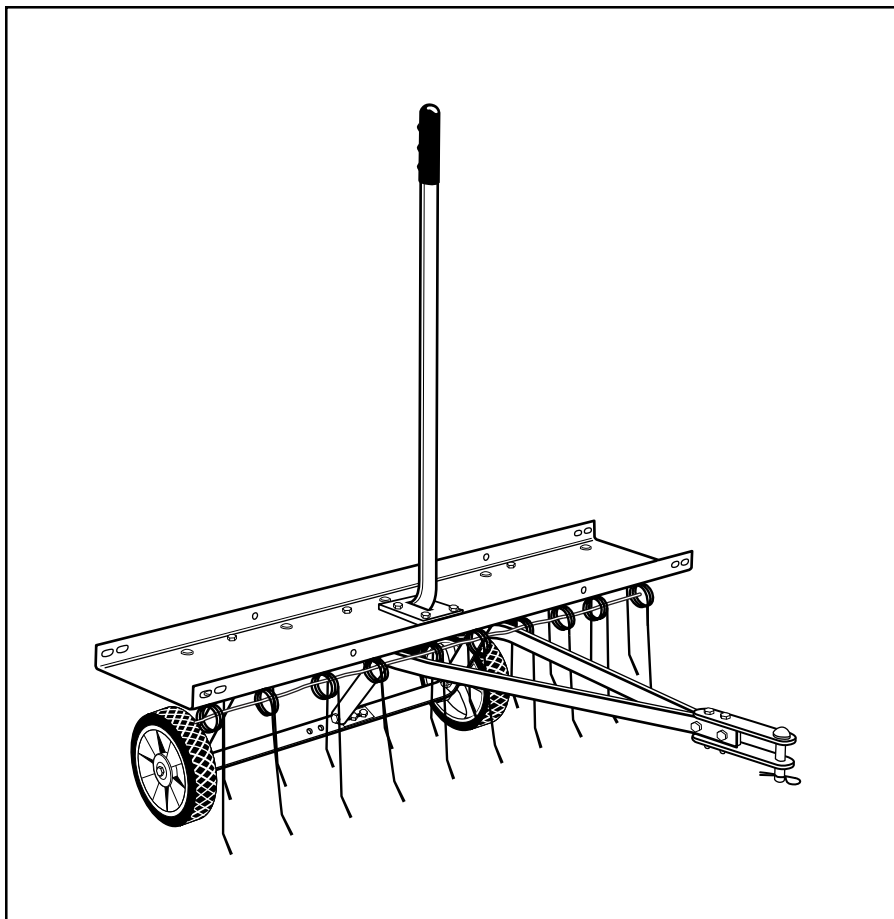

TINE DE-THATCHER

CAUTION:
Read Rules for
Safe Operation
and Instructions
Carefully

- Assembly
- Operation
- Maintenance
- Repair Parts

RULES FOR SAFE OPERATIONS

Remember, any power equipment can cause injury if operated improperly or if the user does not understand how to operate the equipment.



LOOK FOR THIS SYMBOL TO POINT OUT IMPORTANT SAFETY PRECAUTIONS. IT MEANS -- ATTENTION! BECOME ALERT! YOUR SAFETY IS INVOLVED.



CAUTION: VEHICLE BRAKING AND STABILITY MAY BE AFFECTED WITH THE ADDITION OF AN ACCESSORY OR AN ATTACHMENT. BE AWARE OF CHANGING CONDITIONS ON SLOPES.

Exercise caution at all times when using power equipment.

1. Read this owners manual carefully for operating and service instructions before attempting to assemble or operate this equipment. Be thoroughly familiar with the proper use of this equipment.
2. Read the vehicle owners manual and vehicle safety rules, and know how to operate the vehicle before using this equipment.
3. Never allow children to operate the tractor or de-thatcher attachment, and do not allow adults to operate without proper instructions.
4. This de-thatcher attachment has sharp tine points. Always handle with care and wear substantial foot wear when operating this de-thatcher.
5. Do not allow anyone to ride or sit on de-thatcher attachment frame or on towing vehicle.
6. Keep the area of operation clear of all persons, particularly small children, and also pets.
7. Always begin with the transmission in first (low) gear and engine at low speed, and gradually increase speed as conditions permit.
8. The vehicle braking and stability may be affected with the attachment of this equipment. Be aware of changing conditions on slopes. Refer to safety rules in the vehicle owner's manual concerning safe operation on slopes. **STAY OFF OF STEEP SLOPES.**
9. Always operate up and down a slope, never across the face of a slope
10. This equipment should be operated at reduced speed on rough terrain, along creeks and ditches and on hillsides, to prevent tipping and loss of control. Do not drive too close to a creek or a ditch.
11. Do not tow this equipment on a highway or any other public thoroughfare.
12. Follow the maintenance instructions as outlined in this owners manual.

LOOSE PARTS IN CARTON

- | | |
|-----------------------------------|---------------------------------|
| 1. Tine Shield | 6. Lift Plate |
| 2. Spring Tines (10,40") (12,48") | 7. Hitch Brackets (2) |
| 3. Lift Handle | 8. Hitch Arm Mount Brackets (3) |
| 4. Axle Bracket | 9. Hitch Mount Arms (2) |
| 5. Wheels (2) | 10. Spring Alignment Wires (2) |

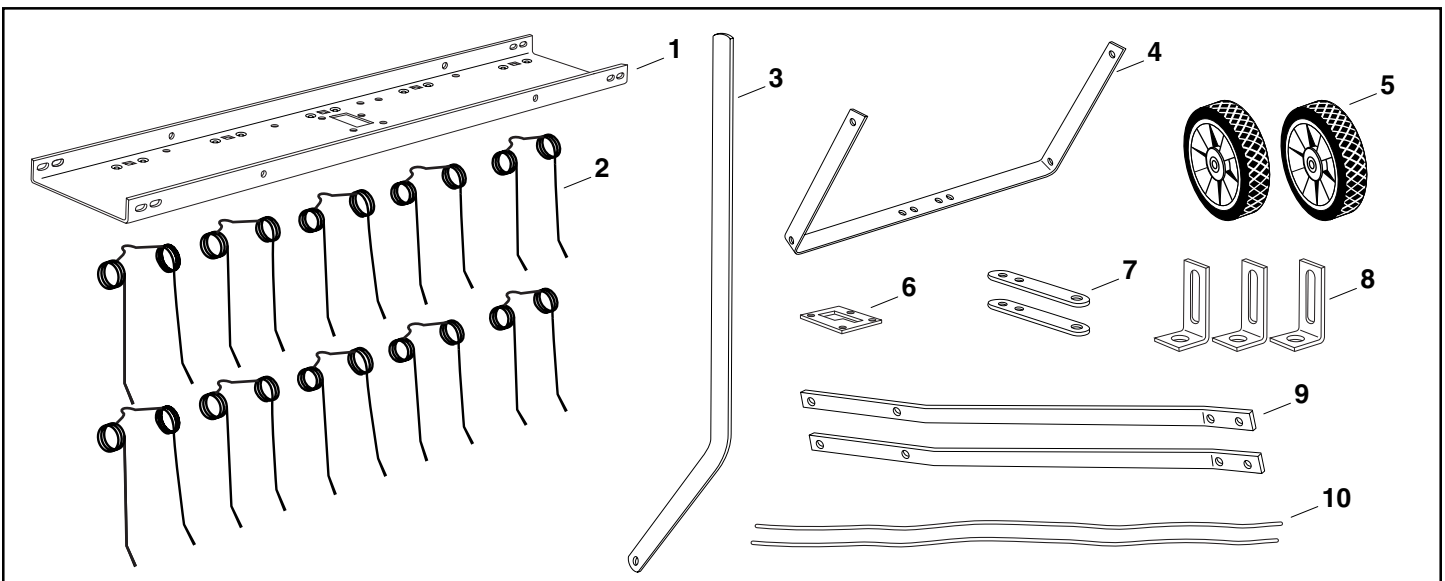

Carton Contents

SHOWN FULL SIZE

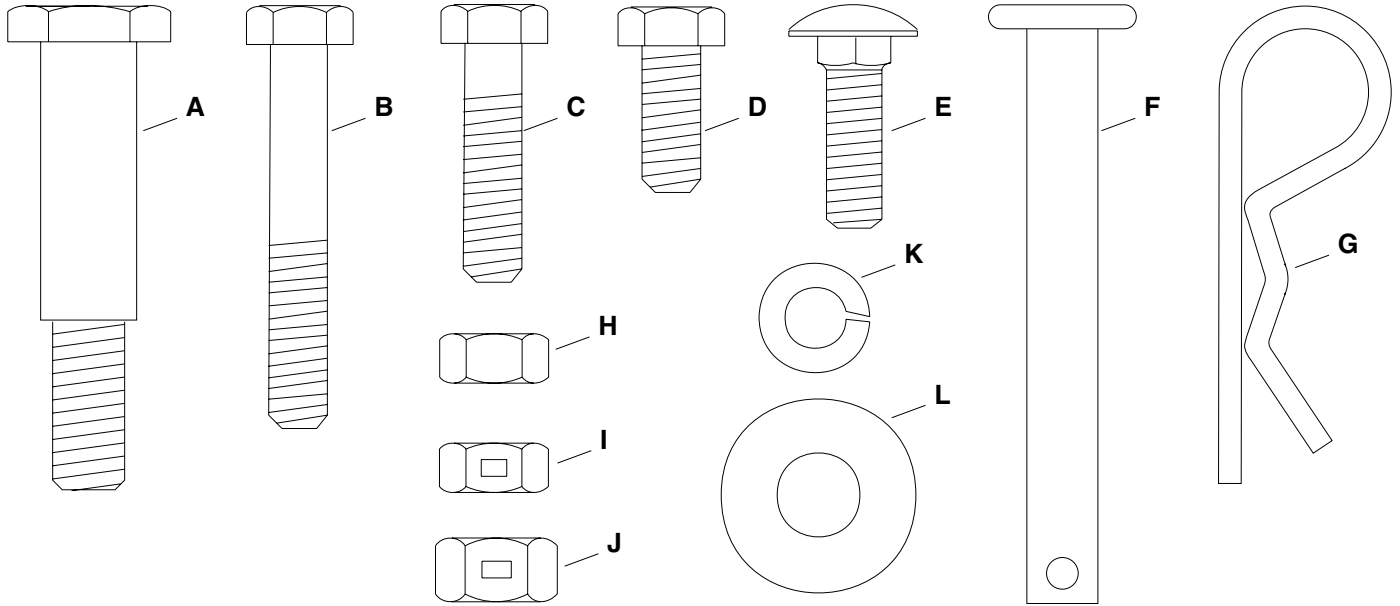

NOT SHOWN FULL SIZE

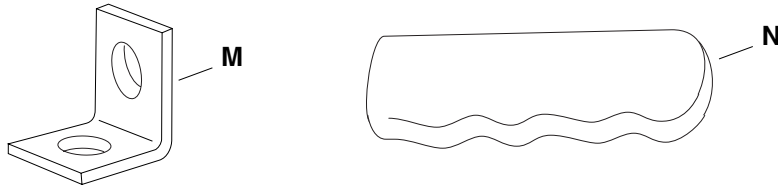

HARDWARE PACK

Key	Qty.		Description	Key	Qty.		Description
	40"	48"			40"	48"	
A	2	2	Shoulder Bolt	I	19	19	Hex Lock Nut, 5/16"
B	2	2	Hex Bolt, 5/16" x 2" Lg.	J	2	2	Hex Lock Nut, 3/8"
C	2	2	Hex Bolt, 5/16" x 1-1/4" Lg.	K	14	16	Lock Washer, 5/16"
D	15	15	Hex Bolt, 5/16" x 3/4" Lg.	L	10	12	Flat Washer, 3/8"
E	14	16	Carriage Bolt, 5/16" x 1"	M	4	4	Angle Bracket
F	1	1	Hitch Pin, 3/8"	N	1	1	Grip
G	1	1	Hair Cotter Pin, 1/8"				
H	14	16	Hex Nut, 5/16"				

ASSEMBLY INSTRUCTIONS

TOOLS REQUIRED FOR ASSEMBLY

- (2) 1/2" wrenches
- (1) 9/16" wrench
- (1) 3/4" wrench or adjustable wrench
- (1) Pliers

Before assembling the de-thatcher, lay out all of the parts and hardware as shown on the previous pages.

The 40" de-thatcher is shown in the following drawings. The assembly of the 40" and 48" is the same except as noted in the instructions.

1. Assemble the lift plate to the top of the tine shield using four 5/16" x 3/4" hex bolts and 5/16" hex lock nuts as shown in figure 1. **Tighten.**

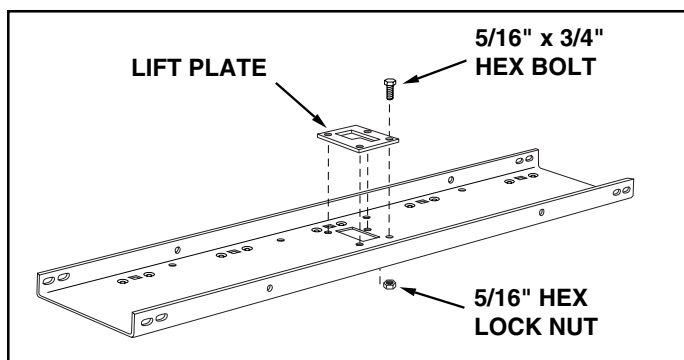

FIGURE 1

2. Turn the tine shield upside down. See figure 2.
3. Assemble two (tall) hitch arm mount brackets and two (short) angle brackets to the bottom of the tine shield. Fasten the brackets to the four **round holes** at the rear of the tine shield using four 5/16" x 3/4" hex bolts and 5/16" hex lock nuts. **Do not tighten yet.** See figure 2.
4. Assemble two angle brackets to the **round holes** in the bottom of the tine shield at the front. Use two 5/16" x 3/4" hex bolts and 5/16" hex lock nuts. **Do not tighten yet.** See figure 2.

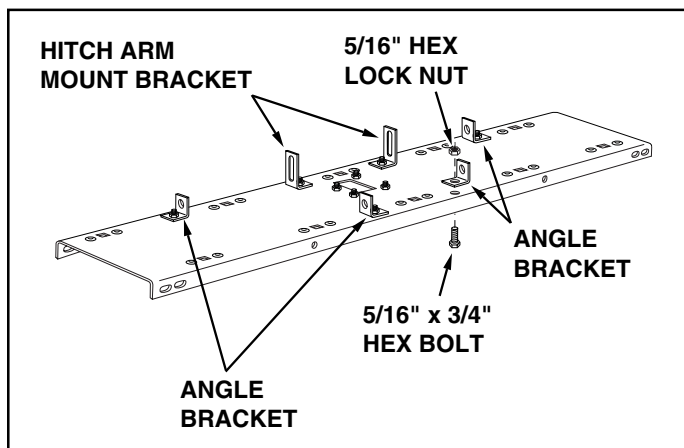

FIGURE 2

5. Fasten the hitch mount arms to the outside of the angle brackets at the front of the tine shield. Use two 5/16" x 3/4" hex bolts and 5/16" hex lock nuts. **Tighten** and then **loosen** the nuts slightly. See figure 3.
6. Fasten the hitch mount arms to the outside of the hitch arm mount brackets at the rear of the tine shield. Use two 5/16" x 1" carriage bolts, 5/16" lock washers and 5/16" hex nuts. **Do not tighten yet.** See figure 3.

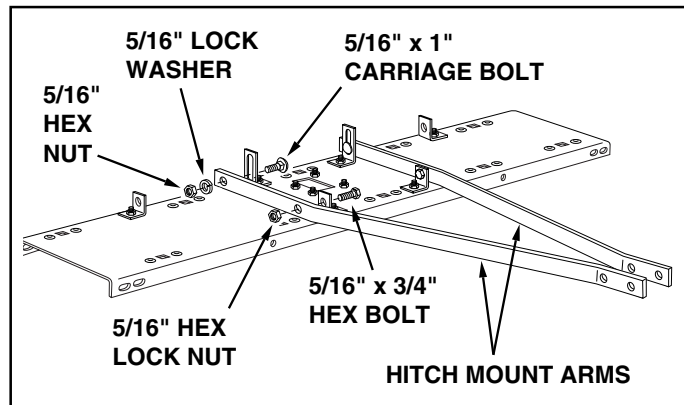

FIGURE 3

7. Assemble the front ends of the hitch mount arms together using two 5/16" x 1-1/4" hex bolts and 5/16" hex lock nuts. **Do not tighten yet.** See figure 4.
8. Assemble the hitch brackets to the top and bottom of the hitch mount arms using two 5/16" x 2" hex bolts and 5/16" hex lock nuts. **Do not tighten yet.** See figure 4.
9. Assemble the 3/8" hitch pin through the hitch brackets and secure it with a 1/8" hair cotter pin. See figure 4.

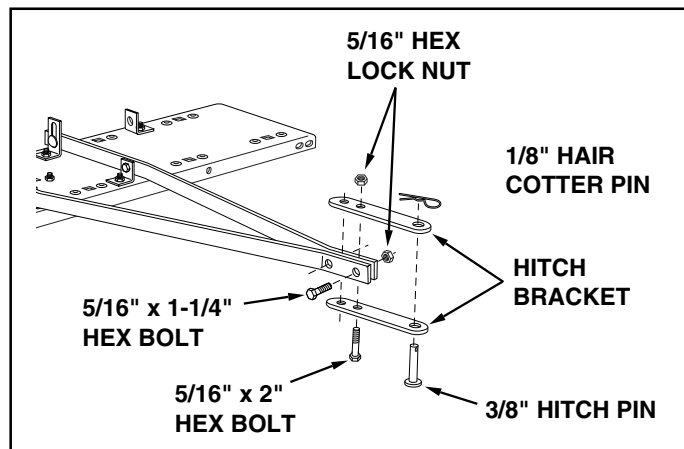

FIGURE 4

10. **Tighten** the bolts and nuts assembled in step 8. **Tighten** the bolts and nuts assembled in step 7. **Tighten** the bolts and nuts assembled in step 3. **Tighten** the bolts and nuts assembled in step 4. **Tighten** and then **loosen** slightly the bolts and nuts assembled in step 5. **Tighten** the bolts and nuts assembled in step 6.

11. Assemble the axle bracket on the outside of the angle brackets using two 5/16" x 3/4" hex bolts and 5/16" hex lock nuts. The ends of the axle bracket must point as shown in figure 5. **Tighten** and then **loosen** the bolts and nuts slightly.

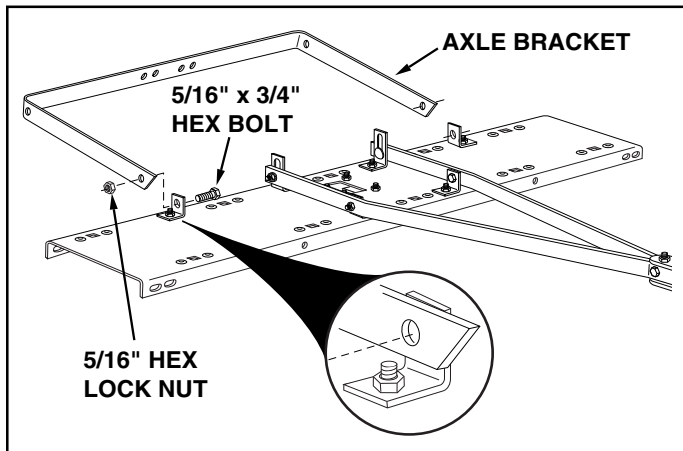

FIGURE 5

12. Assemble the wheels to the axle bracket using two shoulder bolts and two 3/8" hex lock nuts. **Tighten**. See figure 6.

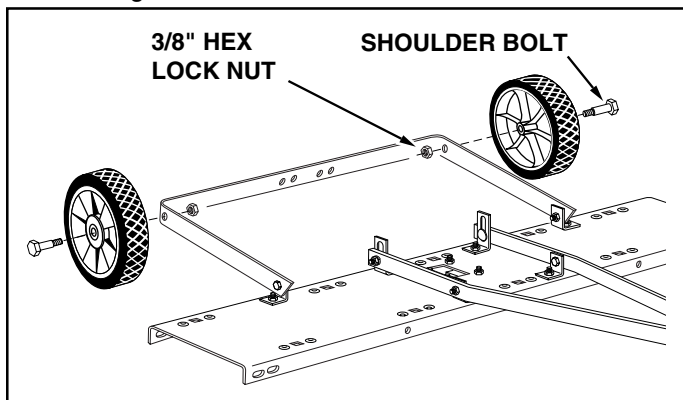

FIGURE 6

13. Fasten ten spring tines (twelve spring tines on the 48") to the square holes in the bottom of the tine shield. Use a 5/16" x 1" carriage bolt, 3/8" flat washer, 5/16" lock washer and 5/16" hex nut for each spring tine. **Tighten**. See figure 7. **NOTE:** Spring tines must seat between dimples.

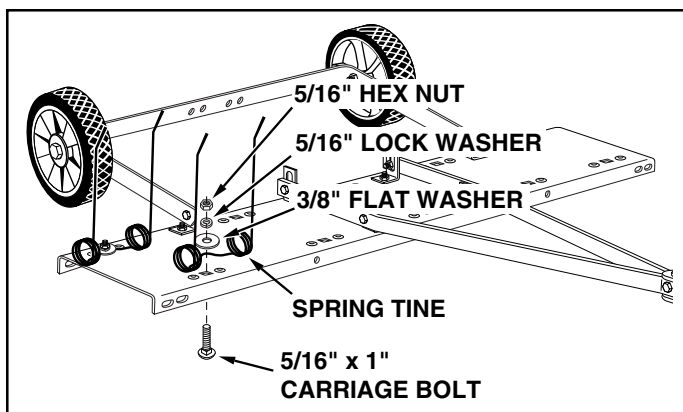

FIGURE 7

14. Assemble the spring align wires through the front and rear rows of spring tines, passing the wires in between the hitch mount arms and the tine shield. Bend the ends of the wires to secure them. See figure 8.

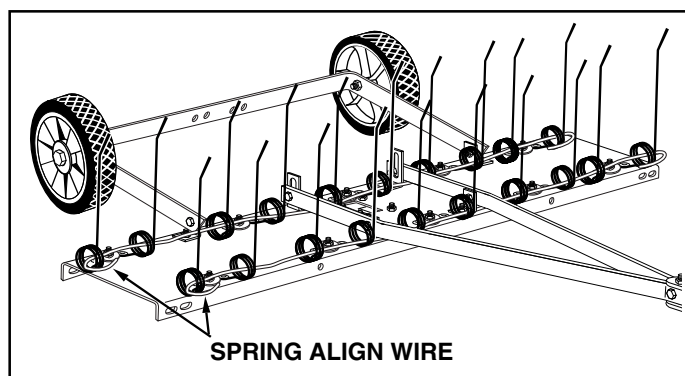

FIGURE 8

15. Assemble a hitch arm mount bracket to the axle bracket using two 5/16" x 1" carriage bolts, 5/16" lock washers and 5/16" hex nuts. **Do not tighten yet**. See figure 9.
16. Insert the lift handle down through the tine shield. Attach it to the just assembled hitch arm mount bracket using a 5/16" x 3/4" hex bolt and a 5/16" hex lock nut. **Tighten**. See figure 9.
17. Position the hitch arm mount bracket so that there is side tension on the lift handle when it is locked in the up position. **Tighten** the nuts. See figure 9.
18. Assemble the grip onto the end of the lift handle. See figure 9.

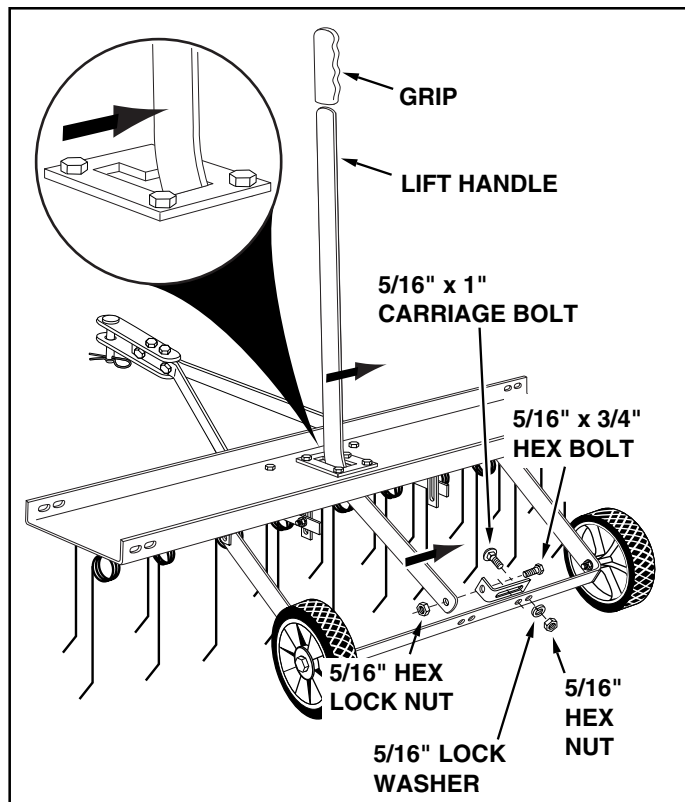

FIGURE 9

OPERATION / ADJUSTMENT

Regular removal of thatch is critical to maintenance of a healthy lawn. Thatch is a layer of stems, clippings, runners, roots and leaves that have not decayed. Excessive thatch prevents air, water and fertilizer from reaching the roots. The de-thatcher effectively dislodges excessive thatch from your lawn. Read these instructions to help avoid improper adjustment and operation.

Proper adjustment of the tine shield and spring tines is important for effective performance. Refer to the following steps for the proper adjustment before operating the de-thatcher.

1. Move the towing vehicle onto a level surface, such as a driveway or garage floor and attach the tine de-thatcher to the vehicle hitch. See figure 10.
2. To adjust the spring tine shield, lower the de-thatcher into operating position using the lift handle. Loosen the two hex nuts and carriage bolts which fasten the rear of the hitch mount arms to the hitch arm mount brackets. Adjust the tine shield until it is level and both the front and rear spring tines are in contact with the ground. Retighten the hex nuts. See figure 10.

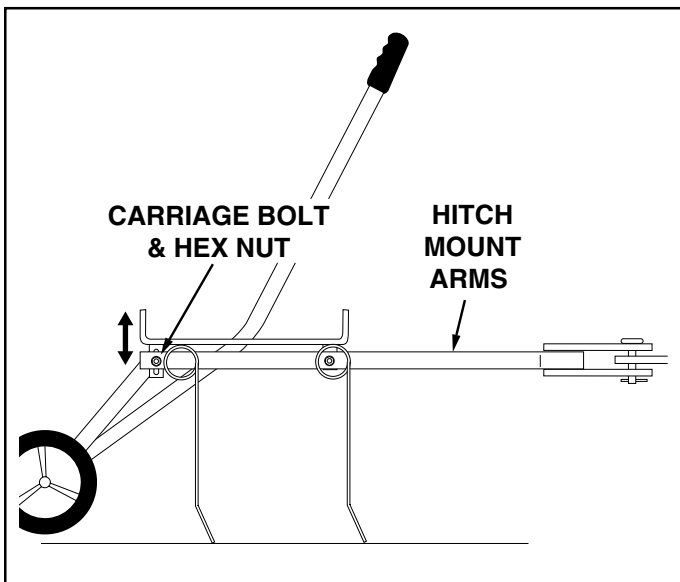

FIGURE 10

3. Vary the vehicle's forward speed until the best dethatching action is achieved.
4. For best results, use a crisscross pattern on your lawn.

5. If the de-thatcher appears to be "jumping" during use, then extra weight should be added to the tine shield. In most conditions extra weight will be needed. Concrete patio blocks are recommended for weight because of their low profile; however any type of weight is suitable if it can be tied down to the shield. Secure weight by using suitable binding material such as rubber tie down straps or wire, fastening to the holes in the shield flange. See figure 11.

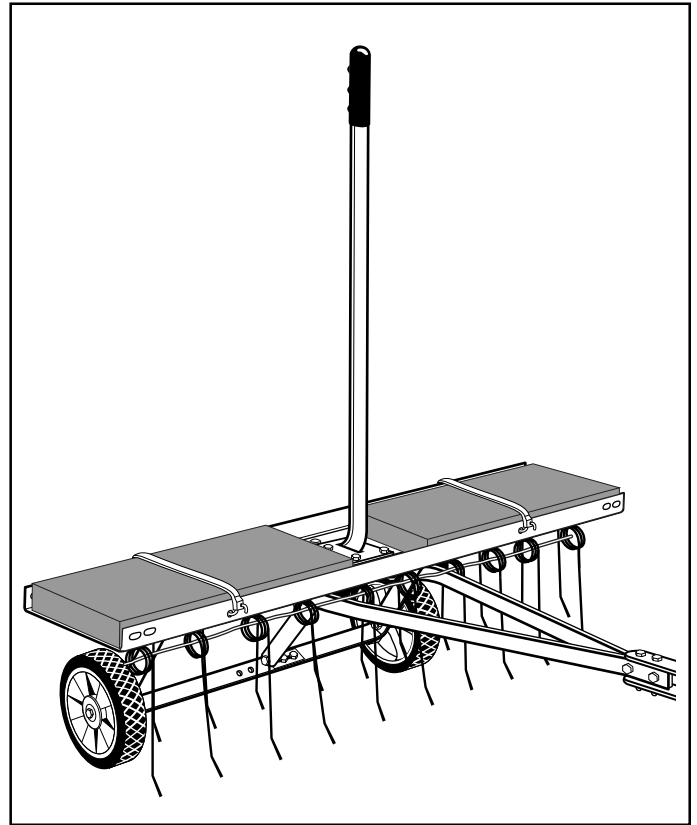

FIGURE 11

MAINTENANCE

1. Before each use check all nuts and bolts for tightness.
2. Lubricate wheels as needed.
3. If rust appears on the shield or spring tines, sand lightly and coat with enamel paint.
4. Always store in a dry area, and coat exposed metal with light oil when not in use.

TINE DE-THATCHER REPAIR PARTS

MODEL NO's. 45-0294 (40") & 45-0295 (48")

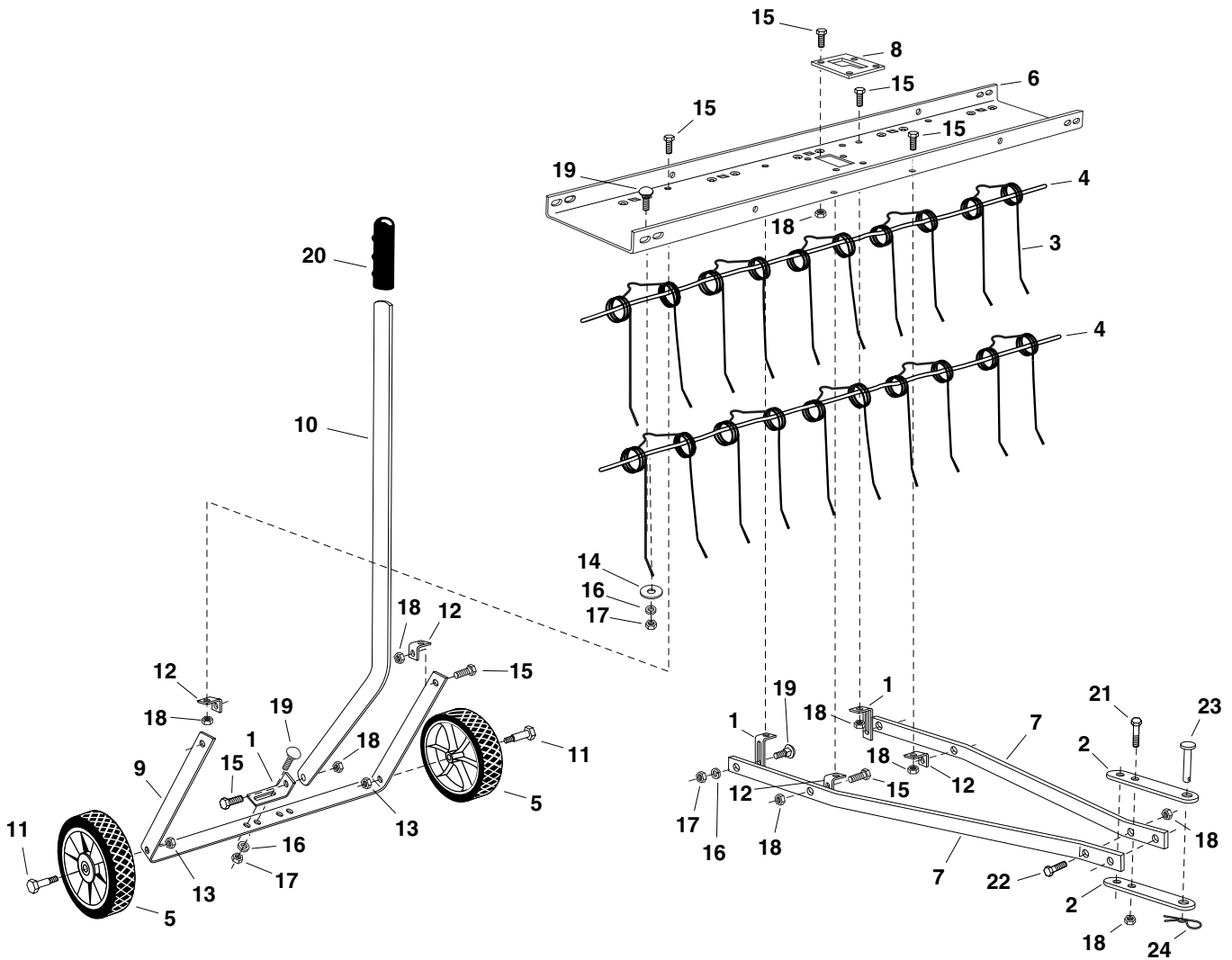

REF. NO.	PART NO.	QTY.		DESCRIPTION	REF. NO.	PART NO.	QTY.		DESCRIPTION
		40"	48"				40"	48"	
1	23442	3	3	Hitch Arm Mount Bracket	13	43082	2	2	Hex Lock Nut, 3/8-16
2	23981	2	2	Hitch Bracket	14	43070	10	12	Flat Washer, 3/8"
3	43783	10	12	Spring Tine	15	43182	15	15	Hex Bolt, 5/16" x 3/4"
4	47633	2	-	Spring Alignment Wire	16	43086	14	16	Lock washer 5/16"
	47654	-	2	Spring Alignment Wire	17	43083	14	16	Hex Nut, 5/16-18
5	43021	2	2	Wheel	18	43064	19	19	Hex Lock Nut, 5/16-18
6	24593	1	-	Tine Shield (40")	19	44326	14	16	Carriage Bolt, 5/16" x 1"
	24627	-	1	Tine Shield (48")	20	43943	1	1	Handle Grip
7	23914	2	2	Hitch Mount Arm	21	44180	2	2	Hex Bolt, 5/16-18 x 2"
8	24594	1	1	Lift Plate	22	43840	2	2	Hex Bolt, 5/16-18 x 1-1/4"
9	24595	1	1	Axle Bracket	23	47623	1	1	Hitch Pin, 3/8" (Flat Head)
10	24596	1	1	Lift Handle	24	43343	1	1	Hair Cotter Pin, 1/8"
11	43029	2	2	Shoulder Bolt		47634	1	1	Owner's Manual
12	23826	4	4	Angle Bracket					

* Purchase Common Hardware Locally

AGRI-FAB® LIMITED WARRANTY

WHO IS COVERED: This Warranty covers only the original retail purchaser of an AGRI-FAB® product or part. It is not transferable.

HOW LONG DOES COVERAGE LAST: This Warranty remains in force for 1 year from the date of purchase.

WHAT IS COVERED: Any defect in material or workmanship of your AGRI-FAB® product or part.

WHAT IS NOT COVERED:

1. This warranty does not apply to the engine or components parts thereof. Please refer to the applicable manufacturer's warranty on these items
2. Transportation charges for the movement of any power equipment unit or attachment are the responsibility of the purchaser. Transportation charges for any parts submitted for replacement under this warranty must be paid by the purchaser unless such return is requested by AGRI-FAB®.
3. This Warranty applies only to products, which have been properly assembled, adjusted, operated, and maintained in accordance with the instructions furnished. This Warranty does not apply to any product, which has been subjected to alteration, misuse, abuse, improper assembly or installation, delivery damage, or to normal wear of the product.
4. Exclusions: Excluded from this Warranty are belts, blades, blade adapters, normal wear, normal adjustments, standard hardware and normal maintenance.
5. AGRI-FAB® does not extend any warranty for products sold or exported outside of the United States of America, its possessions and territories, except those sold through AGRI-FAB's authorized channels of export distribution.

WHAT AGRI-FAB® WILL DO: Repair or replace your AGRI-FAB® product or part.

HOW TO GET SERVICE: Deliver the AGRI-FAB® product or part to AGRI-FAB's local authorized service dealer or distributor. If you do not know the dealer or distributor in your area, please write to the Customer Service Department of AGRI-FAB, Inc. at P.O. BOX 903, SULLIVAN, ILLINOIS 61951. The return of a product or part to AGRI-FAB® will not be accepted unless prior written permission has been extended by AGRI-FAB®.

THE DURATION OF ANY IMPLIED WARRANTY OF MERCHANTABILITY IS LIMITED TO THE DURATION OF THE ABOVE EXPRESS WARRANTY. THE REMEDIES PROVIDED IN THIS LIMITED WARRANTY ARE THE CUSTOMER'S SOLE AND EXCLUSIVE REMEDIES. EXCEPT FOR THE OBLIGATIONS SPECIFICALLY SET FORTH IN THIS LIMITED WARRANTY, IN NO EVENT SHALL AGRI-FAB® BE LIABLE FOR INCIDENTAL OR CONSEQUENTIAL DAMAGES, WHETHER BASED ON CONTRACT, TORT, OR ANY OTHER LEGAL THEORY.

Some states do not allow limitations on how long an implied warranty lasts, or the exclusion or limitation of incidental or consequential damages, so the above limitations may not apply to you.

This Warranty gives you specific legal rights, and you may also have other rights, which vary from state to state.

Agri-Fab, Inc., 303 West Raymond St., Sullivan, Illinois 61951 - (217) 728-8388 - www.Agri-Fab.com

REPAIR PARTS
303 West Raymond
Sullivan, IL. 61951
217-728-8388
www.agri-fab.com