

SAFETY PRECAUTIONS

1. **Never** attach a garden hose to the fill/drain hole when filling. Dangerous pressure build up could occur inside roller.
2. Do not fill roller to maximum weight without checking capability of vehicle to safely pull and stop.
3. Never use roller up and down hills; always work across hills and slopes.
4. Use caution when turning, slowing or stopping.
5. Always drain roller to keep from freezing.

SPECIFICATIONS:

- Roller Drum:** 24" Dia. x 36" Wide, Welded Steel
O.A. Width: Approximately 40"
Bearings: 1" I.D., Replaceable
Tow Hitch: Std. Pin Type - 1/2" Hole
Weight w/ Water: Up to 640 Lbs. Filled with Water
 (Note: May be filled with sand)
Approx. Sh. Wt.: Approximately 105 Lbs.

ASSEMBLY INSTRUCTIONS

(SEE ILLUSTRATION BELOW)

1. Assemble bearings (Ref. 5) into hitch tubes (Ref. 3) so that bearing flange is against outside of hitch tube. (You may need to place a block of wood against bearing and carefully tap with a hammer.)
2. Place hitch tubes (Ref. 3) onto both ends of roller shaft. Assemble a flat washer (Ref. 6) onto each end of roller shaft and secure with two cotter pins (Ref. 12).
3. Assemble scraper bar (Ref. 2) to hitch tubes (Ref. 3) using two hex bolts (Ref. 9) and hex lock nuts (Ref. 10). **Do not tighten yet.**
4. Assemble ends of hitch tubes (Ref. 3) together using two hex bolts (Ref. 7) and hex lock nuts (Ref. 10). **Do not tighten yet.**
5. Assemble hitch brackets (Ref. 4) to hitch tubes (Ref. 3) using two hex bolts (Ref. 8) and hex lock nuts (Ref. 10). **Do not tighten yet.**
6. **Tighten** bolts and nuts starting with scraper bar (Ref. 2), then ends of hitch tubes (Ref. 3), and finally hitch brackets (Ref. 4).
7. Install hitch pin (Ref. 13) through hitch brackets (Ref. 4) and secure with hair cotter pin (Ref. 14).

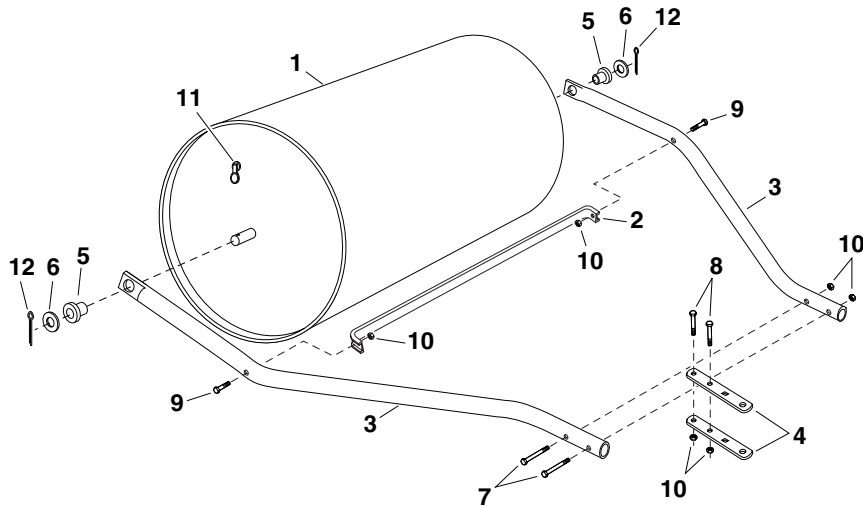

SpeedPart *the fastest way to purchase parts* www.speedepart.com

Ref. No.	Part No.	Qty.	Description	Ref. No.	Part No.	Qty.	Description
1	62377	1	Roller Ass'y	8	43224	2	Hex Bolt, 5/16-18 x 2-1/4"
2	24867	1	Scraper Bar	9	43084	2	Hex Bolt, 5/16-18 x 1-3/4"
3	48361	2	Hitch Tube	10	43064	6	Hex Lock Nut, 5/16-18
4	24192	2	Hitch Bracket	11	43709	1	Plug, Lawn Roller
5	43632	2	Bearing, Plastic	12	43501	2	Cotter Pin, 5/32" x 1-1/2"
6	43528	2	Flat Washer, 1"	13	47623	1	Hitch Pin
7	46782	2	Hex Bolt, 5/16-18 x 3"	14	43343	1	Hair Cotter Pin 1/8"

REPAIR PARTS

303 West Raymond
 Sullivan, IL. 61951
 217-728-8388
www.agri-fab.com