

owners manual

**Model No.
45-01761**

IMPORTANT:

Read Rules for
Safe Operation
and Instructions
Carefully

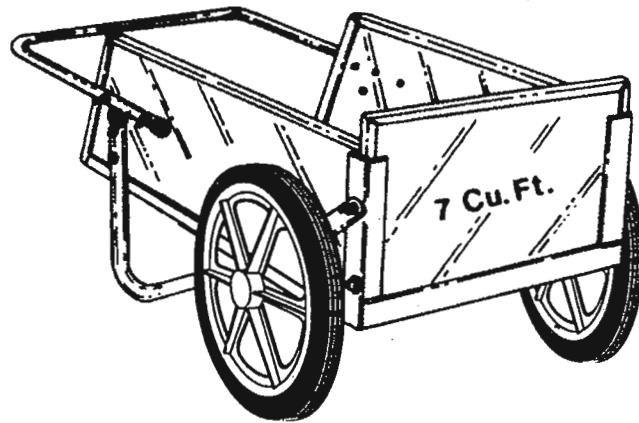

7 CU FT. FARM/YARD CART

- **Assembly**
- **Maintenance**
- **Repair Parts**

Agri-Fab
INC

• 303 WEST RAYMOND • SULLIVAN, ILLINOIS 61951

RULES FOR SAFE OPERATION

Preventing accidents is the responsibility of every equipment operator. The following general safety precautions must be fully understood and followed by every operator.

1. Do not at anytime carry passengers in this cart. It is designed for carrying materials only and not intended to carry passengers.
2. Be careful on any grade (hill) and stay off of steep grades.
3. Use caution when loading cart to avoid tipping.
4. Avoid large holes and ditches when transporting loads.

Your Farm/Yard Cart carton contains a hardware package with parts as shown in the chart below and figure 1.

Contents of Hardware Pack: (See figure 1)

REF. NO.	QTY.	DESCRIPTION
A	13	Screws, 1/4-20 x 3/4" Long
B	25	Flat Washer 1/4" I.D.
C	25	Hex Nuts 1/4-20 Thread
D	8	Screws, 1/4-20 x 1-3/4" Long
E	2	Cotterpins
F	4	Flat Washers 25/32" I.D. x 1-1/2;; O.D.
G	4	Screws 1/4-20 x 1" Long
H	6	Rubber Cap 1/4" x 3/8" Lg.
I	4	Tube Cap 1" x 1" Lg.

HARDWARE REFERENCE CHART

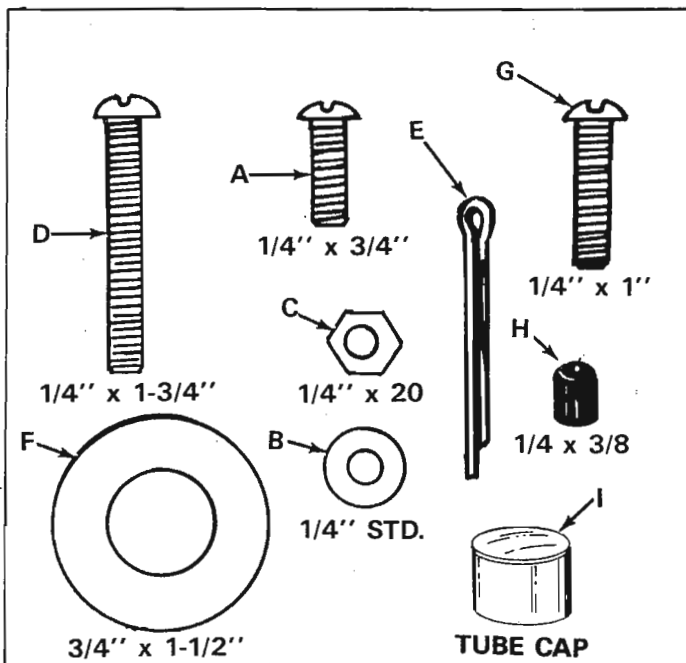

FIGURE 1.

ASSEMBLY INSTRUCTIONS

TOOLS REQUIRED

- (1) Screw Driver
- (1) Pair of Pliers
- (1) 7/16" Open End or Box Wrench

When assembling your cart, place the heads of all screws to the inside and hex nuts with flat washers outside.

1. Lay the front angle assembly down (flat) on floor and stand the bottom panel in position as shown in figure 2.



The bottom panel has one galvanized edge, this is the rear. The front edge has three holes. See figure 2.

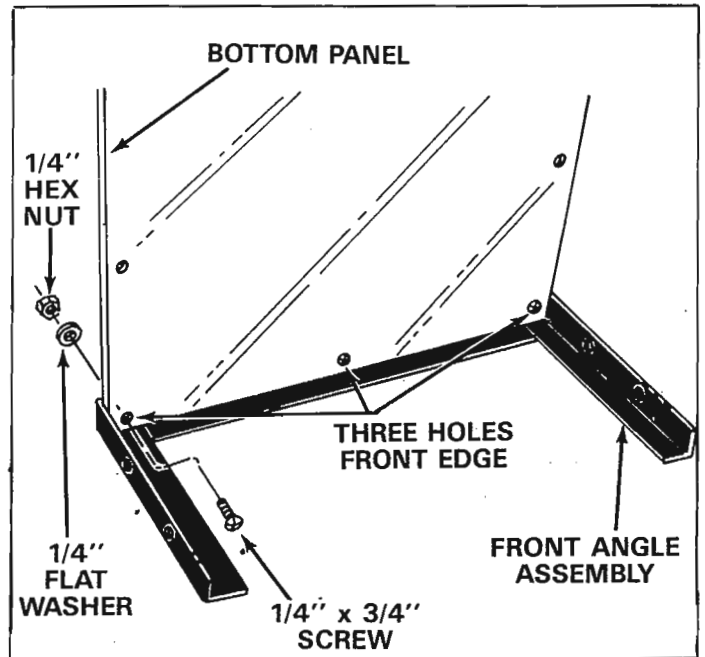

FIGURE 2.

2. Line up three holes in bottom panel with holes in front angle assembly. Start three 1/4" x 3/4" truss head screws through bottom panel, then through angle. Secure screws with flat washers and hex nuts. See figure 2. Tighten securely.

- Turn front angle assembly and bottom panel upside down as shown in figure 3.
- Lay the two side angles on bottom panel so that the axle sleeves are towards the front angle assembly. See figure 3.

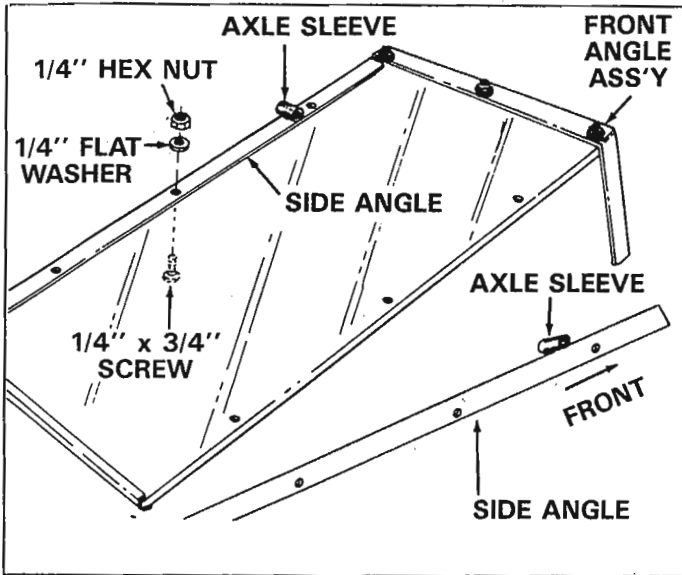

FIGURE 3

- Secure the two side angle assemblies to the bottom panel with six 1/4" x 3/4" truss head screws, flatwashers and hex nuts. Only make finger tight, until all six screws are in place, then tighten securely. See figure 3.
- Stand cart on its front end with front angle assembly on the floor. See figure 4.
- Place four large 1-1/2" dia. flatwashers (used on wheel axle) on the inside of front angle assembly. See figure 4.



These washers act as shims and are just for assembly purposes. You will remove them later.

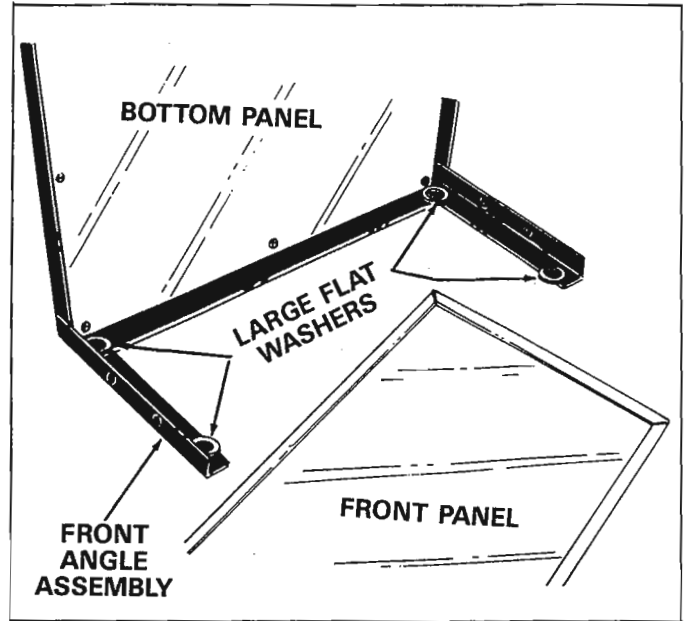

FIGURE 4

- Lay the front panel on top of the four large washers and in the front angle assembly. See figure 5.

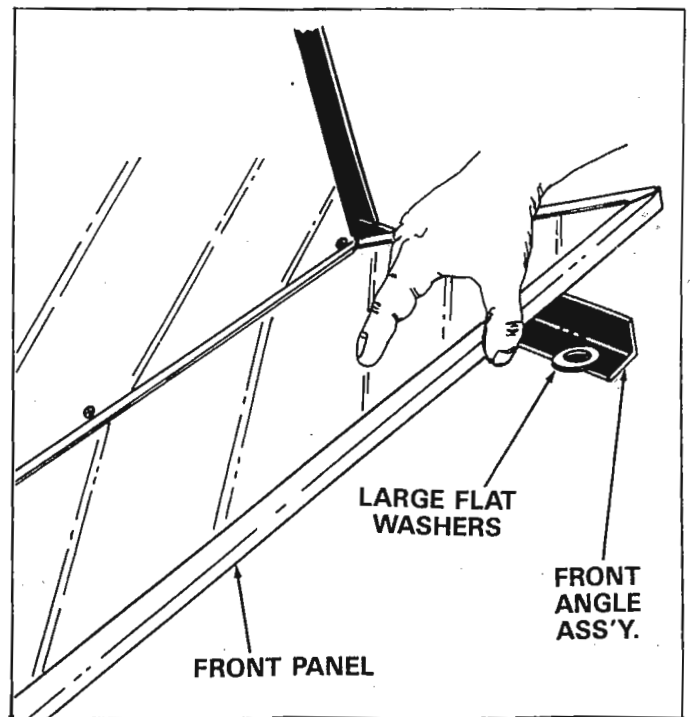

FIGURE 5

- Place one side panel in position, against side angle and down on top of front panel. Start one $1/4'' \times 3/4''$ truss head screw through the center hole in side panel and side angle. Secure with hex nut and flat washer. See figure 6. **Make only finger tight at this time.**

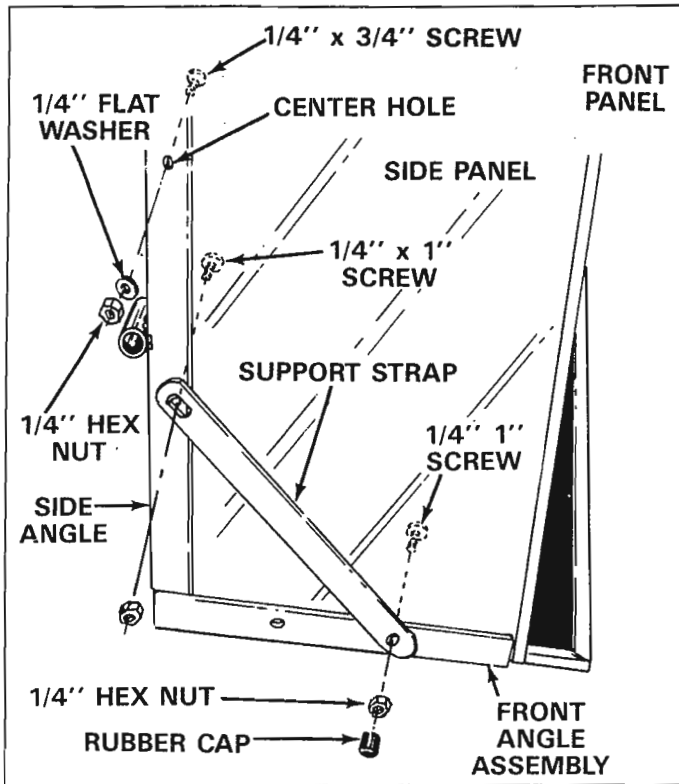

FIGURE 6

- Start one $1/4'' \times 1''$ truss head screw through front hole on side panel and side angle. Start another $1/4'' \times 1''$ truss head screw through top hole on side panel and front angle assembly, next place support strap over these two screws, secure with hex nuts and cover threads of top screw with a rubber cap. See figure 6. **Make only finger tight at this time.**
- Repeat steps 9 and 10 for the other side panel.
- Assemble one $1/4'' \times 3/4''$ truss head screw through bottom hole in side panel and front angle assembly. Secure flat washer and hex nut. See figure 7. **Make only finger tight at this time.**
- Repeat step 12 for the other side panel.
- Place axle through axle sleeves as shown in figure 11 page 5. **Tighten all nuts and screws securely.**

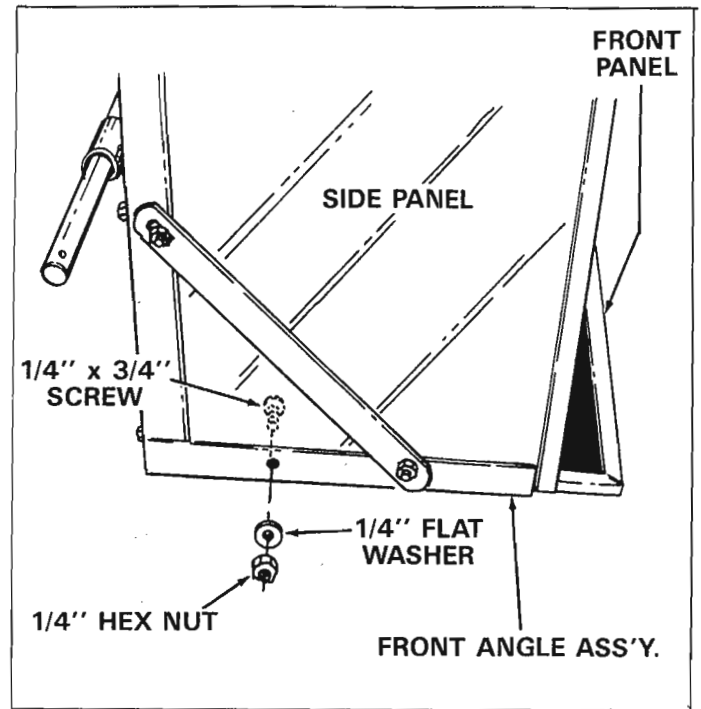

FIGURE 7

- Lay cart down on floor, so that the sides are up in a normal position. Remove the front panel, by sliding it up, and remove the four large washers you used for shims. See figure 8.

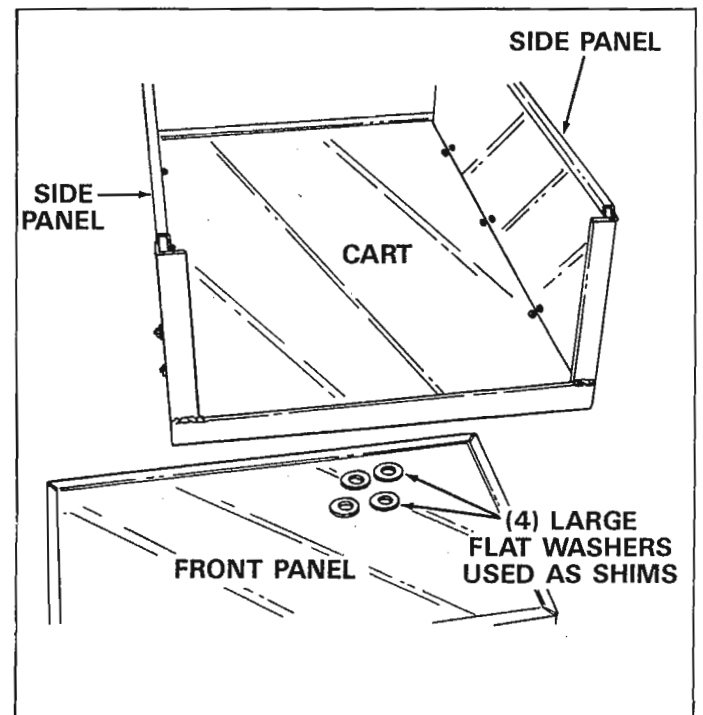

FIGURE 8

- Place tube caps on leg tube and handle as shown in figure 10. Stand cart up on its front end again and assemble the leg tube as shown in figure 9 using four 1/4" x 1-3/4" truss head screws through side panels and leg tube. Secure with flat washers and hex nuts. See figure 9.

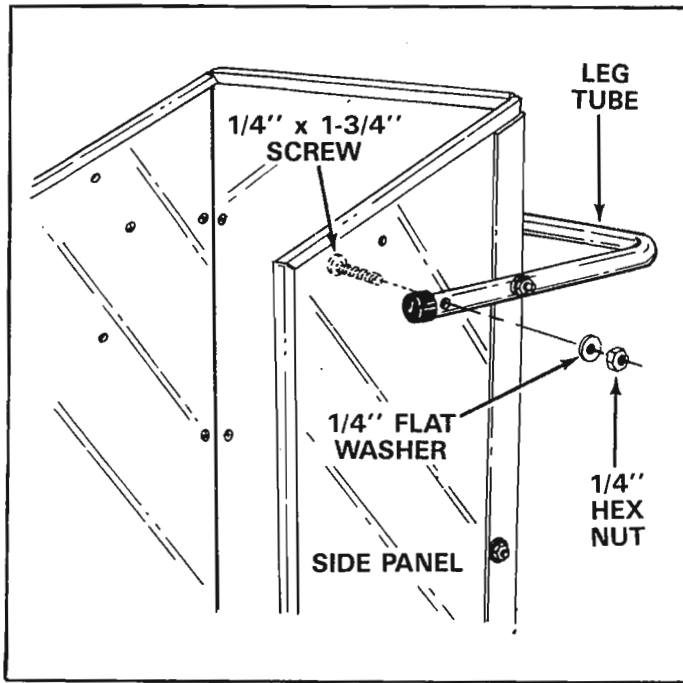

FIGURE 9

- With the cart still standing on its front angle assembly, assemble the handle tube.

- Place the handle tube over the side panels and line up the four holes. Assemble four 1/4" x 1-3/4" truss head screws through the side panels and handle. Secure with flat washers, hex nuts and cover threads with rubber caps. See figure 10.

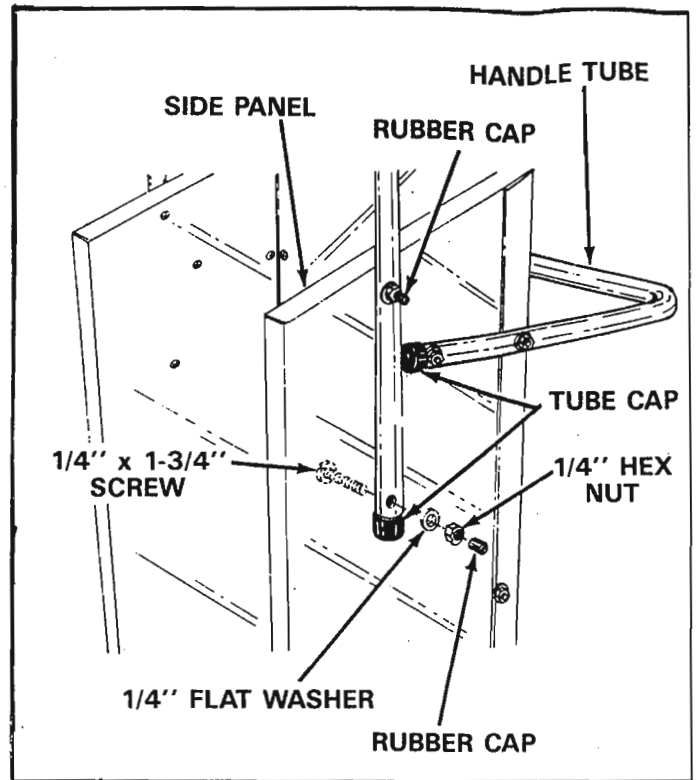

FIGURE 10

- Now lay the cart down, do that it is upside down, to assemble the wheels. See figure 11 and 12.

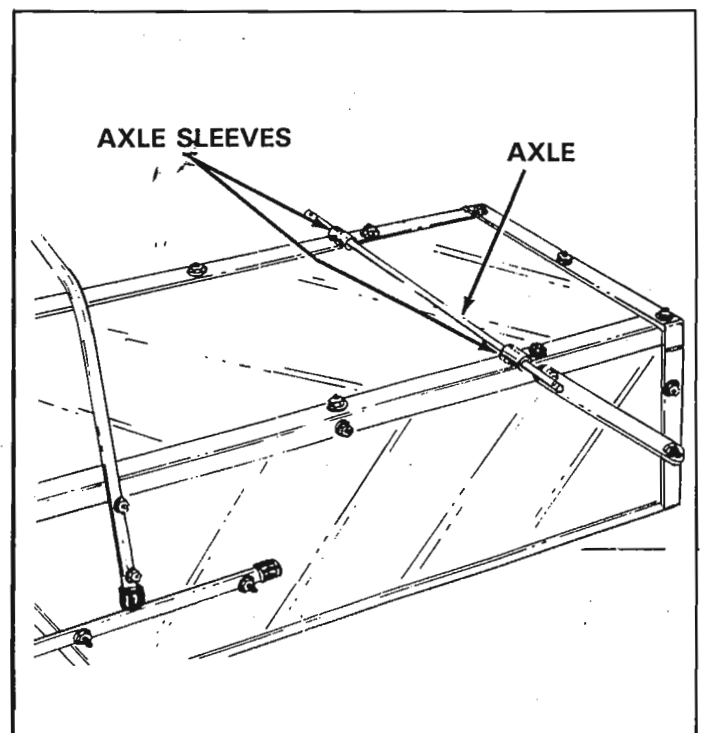

FIGURE 11

20. Place one 1-1/2" dia. flat washer on axle, then wheel, one more large flat washer and secure with cotter pin. See figure 12 and note below. Repeat step for other wheel.

NOTE

If cotter pin can not be assembled through hole in the axle ends, remove one washer from inside, next to sleeve.

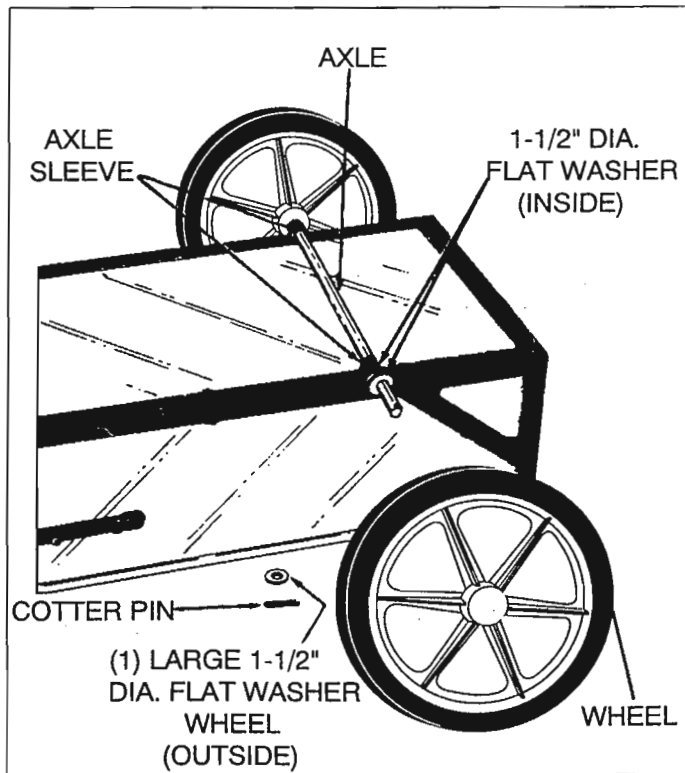

FIGURE 12

21. Turn cart right side up, so that it rests on its wheels.
22. Place front panel in guides to complete assembly.
23. Your cart is now ready to use.

MAINTENANCE

1. Grease or oil wheel bearings occasionally. Use automotive wheel bearing type grease or 20 weight oil.
2. Periodically retighten all screws, especially after heavy use. **Do not exceed load capacity rating of 300 lbs.**
3. Clean cart thoroughly after each use.
4. Store indoors during severe weather.
5. Apply light coat of varnish to all wood surfaces annually.
6. Use glossy black enamel spray paint to touch-up scratched or worn paint surfaces.

MODEL 45-01761 7 CU. FT. FARM/YARD CART

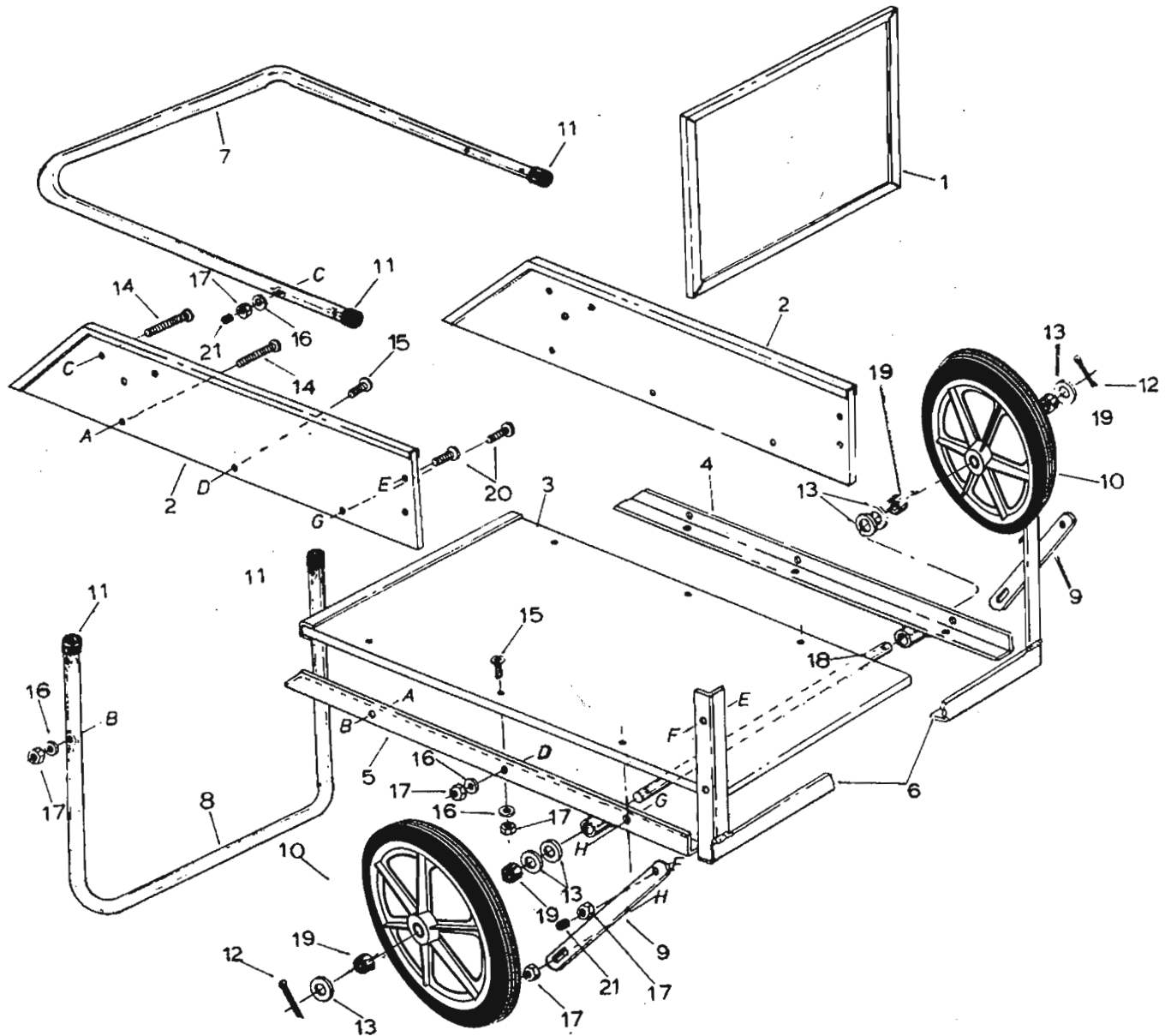

PARTS LIST FOR MODEL NO. 45-01761 FARM/YARD CART

REF. NO.	PART NO.	QTY.	DESCRIPTION	REF. NO.	PART NO.	QTY.	DESCRIPTION
1	44012	1	Front Panel	13	43949	4	Flat Washers 25/32" I.D. x 1-1/2" O.D. x 3/32" Tk.
2	44013	2	Side Panel	14	44022	8	Truss Head Screws 1/4-20 x 1-3/4" Lg.*
3	44014	1	Bottom Panel	15	44023	13	Truss Head Screws 1/4-20 x 3/4" Lg.*
4	62527	1	Side Angle Assembly-L.H.	16	43088	25	Flat Washer 1/4" I.D.*
5	62528	1	Side Angle Assembly-R.H.	17	43178	25	Hex Nut 1/4-20 Thd.*
6	62529	1	Front Angle	18	23991	1	Axle
7	44018	1	Handle Tube	19	44016	4	Bearing, Ball 3/4" I.D.
8	44019	1	Leg Tube	20	44259	4	Truss Head Screws 1/4-20 x 1" Lg.*
9	23606	2	Support Strap	21	44538	6	Rubber Cap 1/4 x 3/8" Lg.
10	44975	2	Wheel Assembly Complete w/bearings (20")		46082	1	Owner's Manual
11	44021	4	Tube Caps				
12	43010	2	Cotter Pin 1/8" x 1-1/4" Lg.*				

*Purchase Common Hardware Locally.

REPAIR PARTS

303 West Raymond Street
Sullivan, Illinois 61951
(217) 728-8388