

OWNERS MANUAL

Model No.
LBD48C
48"
SNOW BLADE

CAUTION:
Read Rules for
Safe Operation
and Instructions
Carefully

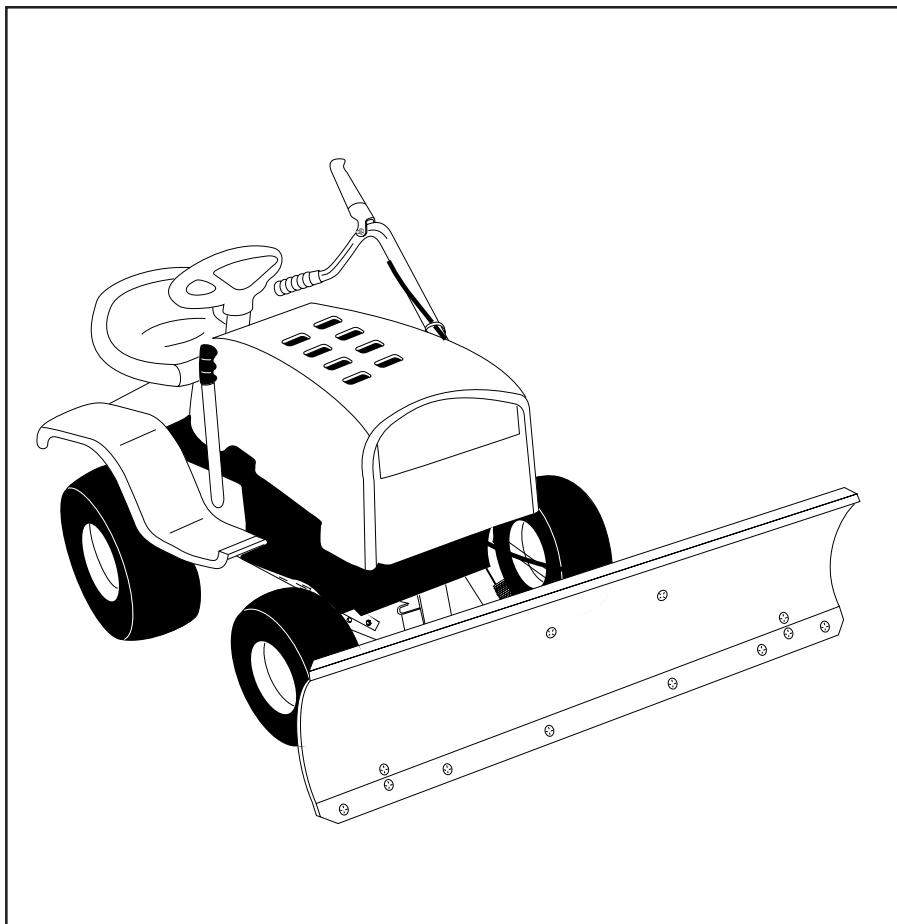

48" SNOW BLADE

RULES FOR SAFE OPERATION

Any power equipment can cause injury if operated improperly or if the user does not understand how to operate the equipment.



LOOK FOR THIS SYMBOL TO POINT OUT IMPORTANT SAFETY PRECAUTIONS. IT MEANS -- ATTENTION! BECOME ALERT! YOUR SAFETY IS INVOLVED.

Exercise caution at all times, when using power equipment.

1. Read the tractor and snow blade owners manuals and know how to operate your tractor before using tractor with snow blade attachment.
2. Never operate tractor and snow blade without wearing proper clothing suited to weather conditions and operation of controls.
3. Never allow children to operate tractor and snow blade, and do not allow adults to operate without proper instructions.
4. Always begin with transmission in first (low) gear and gradually increase speed as required.

CUSTOMER RESPONSIBILITIES

Read and observe the safety rules.

Follow the instructions under "Customer Responsibilities" and "Storage" sections of this manual.

TABLE OF CONTENTS

SAFETY RULES.....	2	OPERATION AND ADJUSTMENTS.....	10-11
CARTON CONTENTS.....	3	CUSTOMER RESPONSIBILITIES.....	12
FULL SIZE HARDWARE CHART.....	4	STORAGE.....	13
ASSEMBLY	5-10	PARTS EXPLOSION.....	14
		REPAIR PARTS.....	15

48" SNOW BLADE CARTON CONTENTS

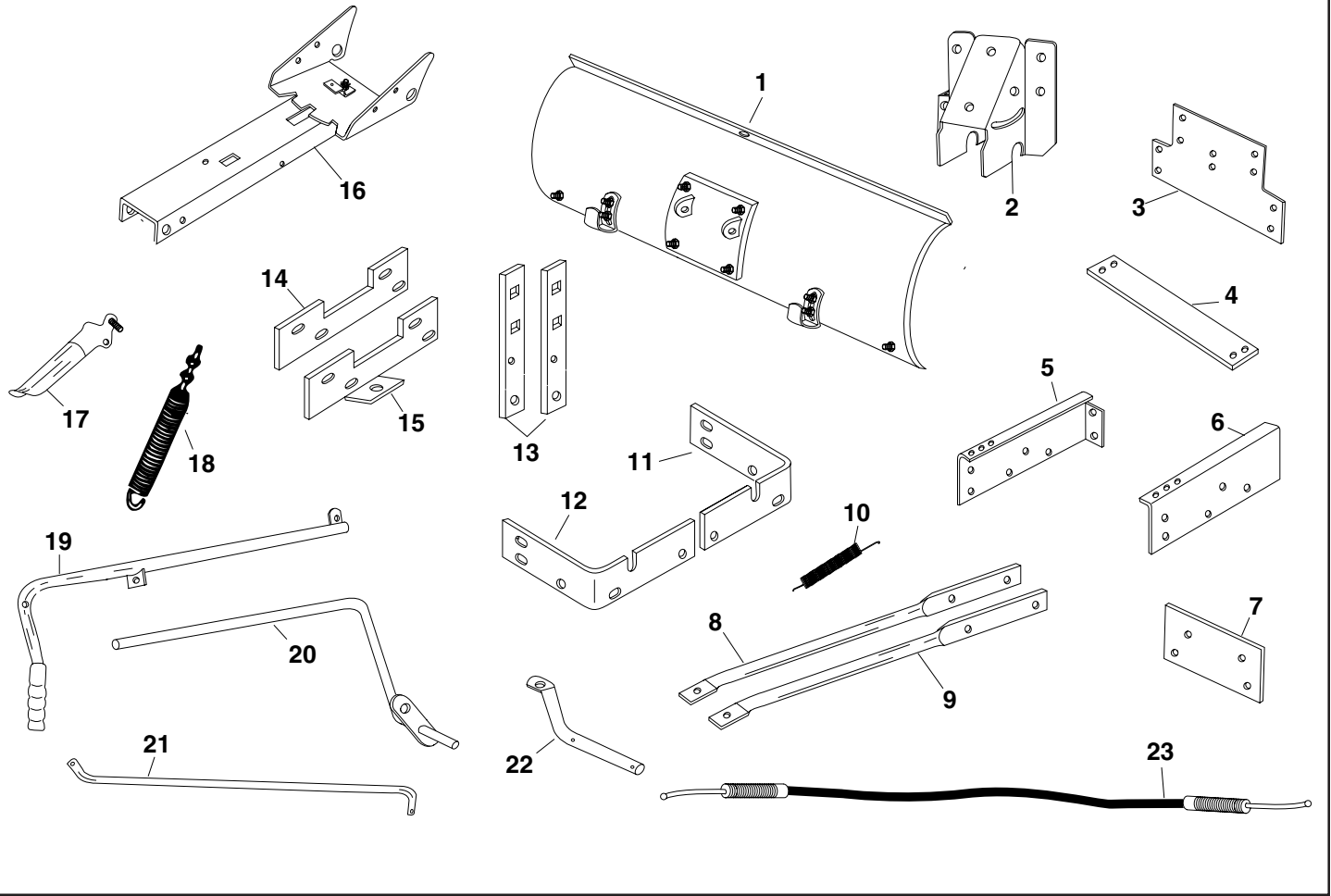









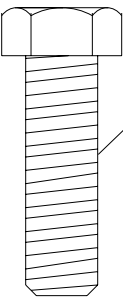
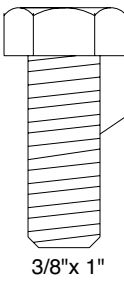
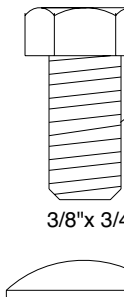
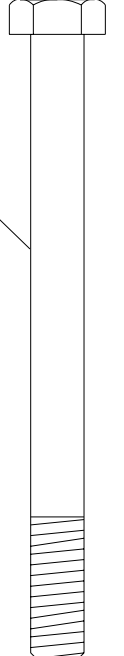
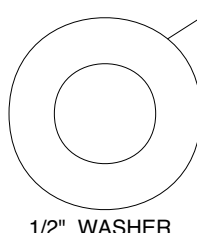

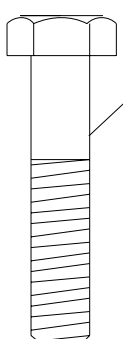
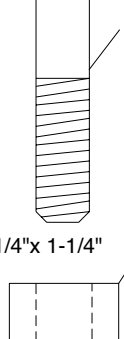
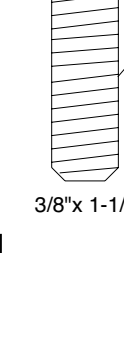
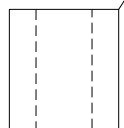

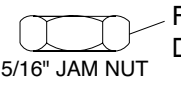
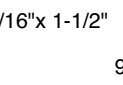
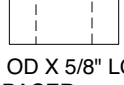
CARTON CONTENTS

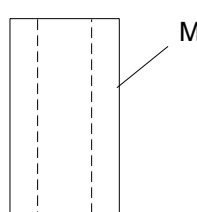
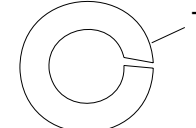
REF. NO.	QTY.	DESCRIPTION	REF. NO.	QTY.	DESCRIPTION
1	1	Blade Assembly	13	2	Angle Lock Bars
2	1	Pivot Support Bracket	14	1	Brace Mount Bracket (L.H.)
3	1	Pivot Support Plate	15	1	Brace Mount Bracket (R.H.)
4	1	Cross Brace	16	1	Channel Assembly
5	1	Frame Pivot Support (L.H.)	17	1	Grip Assembly
6	1	Frame Pivot Support (R.H.)	18	1	Blade Adjust Spring
7	1	Pivot Plate Bracket	19	1	Handle Tube
8	1	Brace Tube (L.H.)	20	1	Lift Rod
9	1	Brace Tube (R.H.)	21	1	Blade Pivot Rod
10	1	Extension spring	22	1	Pivot Shaft
11	1	Frame Reinforcement Bracket, L.H.	23	1	Cable
12	1	Frame Reinforcement Bracket, R.H.		1	Hardware Package (See page 4)

REF.	QTY.	DESCRIPTION
A	1	Spring Mount Rod
B	2	Palnut, 3/8"
C	3	Cotter Pin 1/8" x 1-1/4"
D	1	Angle Lock Spring
E	2	Cable End Fitting
F	4	Hex Jam Nut 5/16 Thread
G	1	Spacer, 9/16" OD x 5/8"
H	1	Hex Bolt, 5/16-18 x 1-1/2"
I	1	Hex Lock Nut 5/16-18 Thread
J	1	Cable Mount Bracket
K	1	Hex Bolt 1/4-20 x 1-1/4"
L	3	Hex Lock Nut 1/4-20 Thread
M	2	Spacer, 9/16" OD x 1" LG.
N	2	Carriage Bolt 3/8-16 x 1-1/4"
O	30	Hex Lock Nut 3/8-16 Thread
P	4	Hairpin Cotter
Q	1	Channel pivot pin
R	1	Lift Link Ass'y
S	18	Hex Bolt 3/8-16 x 1"
T	30	Washer, 3/8" Lock
U	1	Washer 1/2"
V	4	Hex Bolt, 3/8-16 x 1-1/4" LG.
W	6	Hex Bolt, 3/8-16 x 3/4" LG.
X	1	Hex Bolt, 1/4-20 x 3-1/4" LG.
Y	2	Washer, 3/8" STD.
Z	2	Nylon Tie

FIGURE 1 HARDWARE PACKAGE

					
3/8"x 1-1/4"	3/8"x 1"	3/8"x 3/4"	1/4"x 3-1/4"	1/2" WASHER	3/8" LOCK NUT
					
5/16"x 1-1/2"	1/4"x 1-1/4"	3/8"x 1-1/4"	9/16" OD X 5/8" LG. SPACER	3/8" STD WASHER	5/16" JAM NUT
					
5/16"x 1-1/2"	1/4"x 1-1/4"	3/8"x 1-1/4"	9/16" OD X 1" LG. SPACER	3/8" LOCK WASHER	5/16" LOCK NUT
					
5/16"x 1-1/4"	5/16"x 1-1/4"	5/16"x 1-1/4"	5/16"x 1-1/4"		1/4" LOCK NUT

FULL SIZE HARDWARE REFERENCE CHART

ASSEMBLY

TOOLS REQUIRED FOR ASSEMBLY

- (1) Pliers
- (1) Hammer
- (1) Adjustable Wrench (or socket set)
- (1) 9/16" Open End or Box Wrench
- (1) 7/16" Open End or Box Wrench
- (1) 1/2" Open End or Box Wrench

REMOVAL OF PARTS FROM CARTON

- Refer to carton contents figure on page 3 and figure 1 on page 4 for parts and hardware needed to assemble snow blade.

NOTE: Right hand (R.H.) and left hand (L.H.) are determined from operators position while seated in the tractor.

TRACTOR PREPARATION

- Remove mower deck or any other attachment you may have mounted to your tractor. Mark all loose parts and save for reassembly. Refer to owners manual for removal of mower/attachment.

ASSEMBLY OF SNOW BLADE TO TRACTOR

- Assemble frame pivot supports (R.H. and L.H.) to pivot support plate using four 3/8" x 1" hex bolts, lock washers and locknuts. See figure 2.
- Using the inside two holes on the tops of the frame pivot supports, attach the cross brace using four 3/8" x 3/4" hex bolts, lock washers and lock nuts. See figure 2.

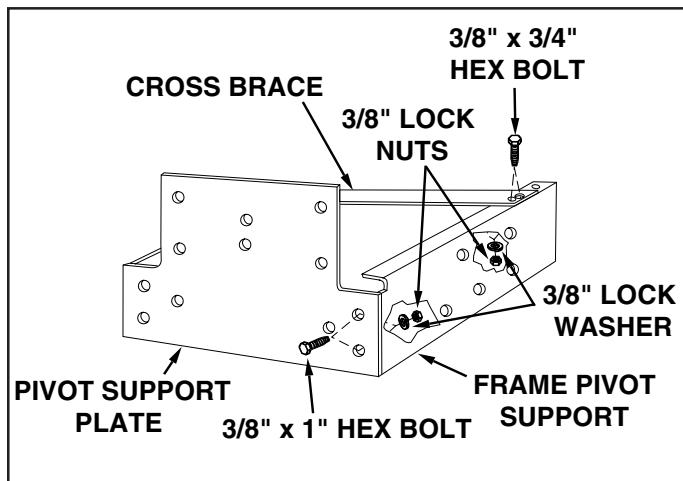

FIGURE 2

- Place the lift link inside the pivot support bracket. The long pin on the lift link goes through the slot in the pivot support bracket. The short pin goes through the hole shown in figure 3. Secure short pin with 1/8" x 1-1/4" cotter pin.

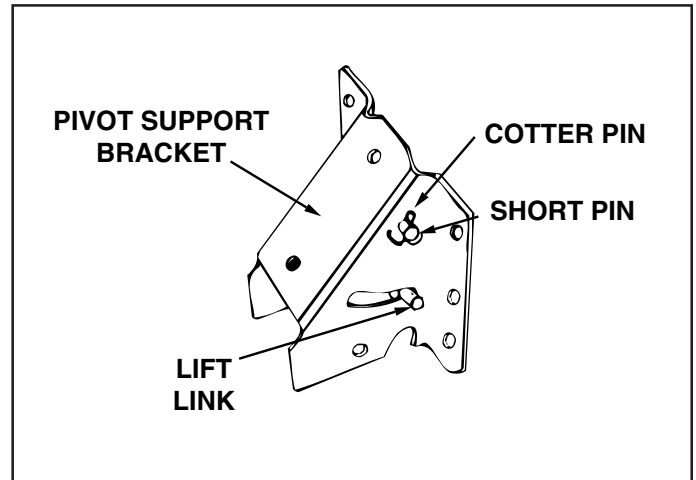

FIGURE 3

- Using the bottom hole on each side, attach the pivot support bracket to outside of pivot support plate using two 3/8" x 1" hex bolts, lock washers and lock nuts. See figure 4.
- Using the top holes on the pivot support plate, assemble the pivot plate bracket to the inside of the plate using two 3/8" x 1-1/4" hex bolts, lock washers and lock nuts. See figure 4.
- Attach the left and right hand tube braces to the inside of the left and right hand frame pivot supports using four 3/8" x 1" hex bolts, lock washers and lock nuts. Both tube braces should angle up and out. **Do not tighten at this time.** See figure 4.

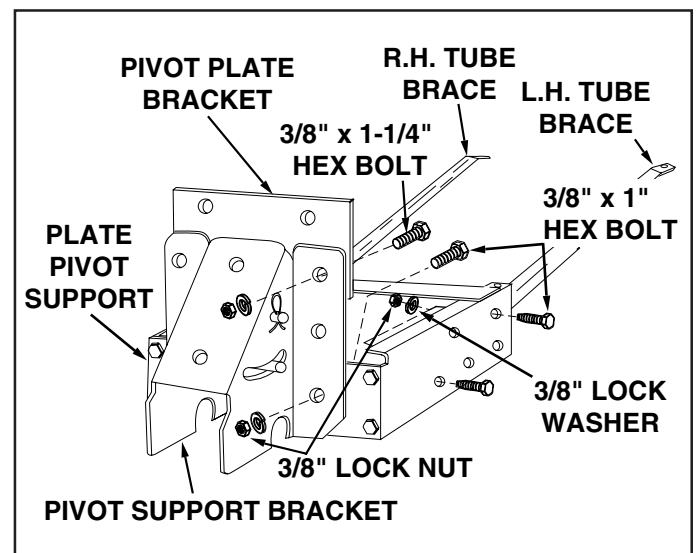

FIGURE 4

NOTE: To attach the frame reinforcement bracket in the next step, the tractor hood can be removed for easier access. Refer to your owner's manual for removal of hood.

- Attach R.H. and L.H. frame reinforcement brackets to front of tractor frame using four 3/8" x 1" hex bolts, four 3/8" lock washers and four 3/8" lock nuts. **Do not tighten.** See figure 5.

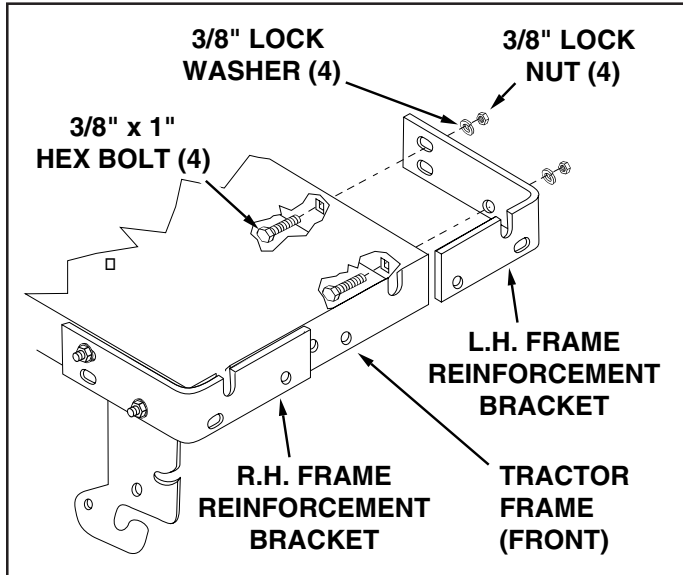

FIGURE 5 (Right hand side view)

- Lower the mower lift assembly.
- Starting at the rear of the foot rest, remove and discard, if present, the two bolts in the bottom set of holes as illustrated in figure 6. Repeat on opposite side foot rest.
- Place a 3/8" x 3/4" hex bolt in ear of both brace mount brackets as shown in figure 6. Now, using the two small bottom slots in the brace mount brackets, attach both brackets (R.H and L.H.) underneath both sides of the tractor frame using four 3/8" x 1" hex bolts, lock washers and lock nuts. (Brackets should be positioned on the inside of the frame with ears to the rear and pointing outward.) **Do not tighten.** See figure 6.

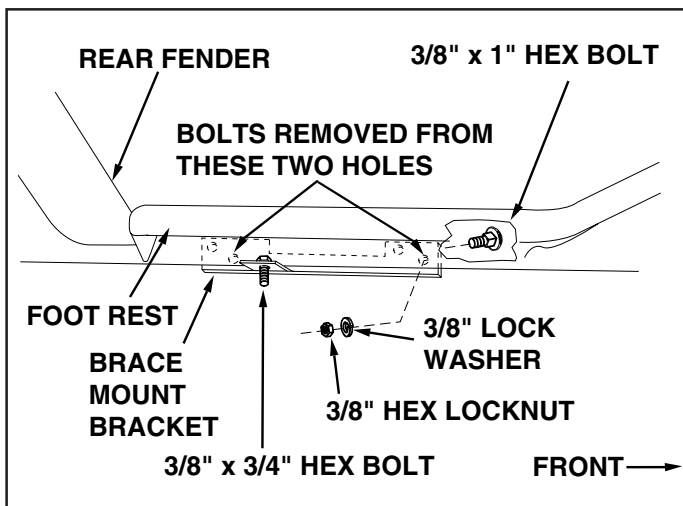

FIGURE 6 (Right Hand Side View)

- Raise the mower lift assembly.
- Slide blade frame assembly under tractor, with the brace tubes at the rear.
- Attach brace tube to brace mount bracket using the 3/8" x 3/4" hex bolt already assembled in previous step. Secure with a 3/8" lock washer and 3/8" lock nut. Repeat this step on opposite side. **Do not tighten at this time.** See figure 7.

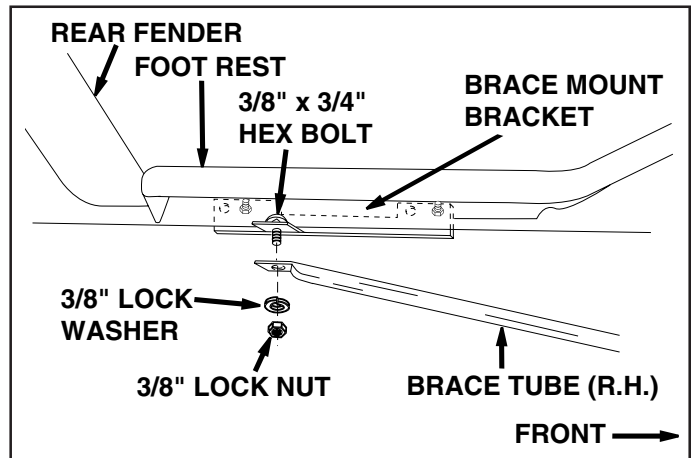

FIGURE 7 (Right Hand Side View)

- Attach blade frame assembly to inside of tractor frame by aligning holes in pivot plate bracket with holes in front end of tractor frame and holes in frame reinforcement brackets. Secure using two 3/8" x 1-1/4" hex bolts, 3/8" flat washers, 3/8" lock washers and 3/8" lock nuts. **Tighten these two bolts at this time.** See figure 8.

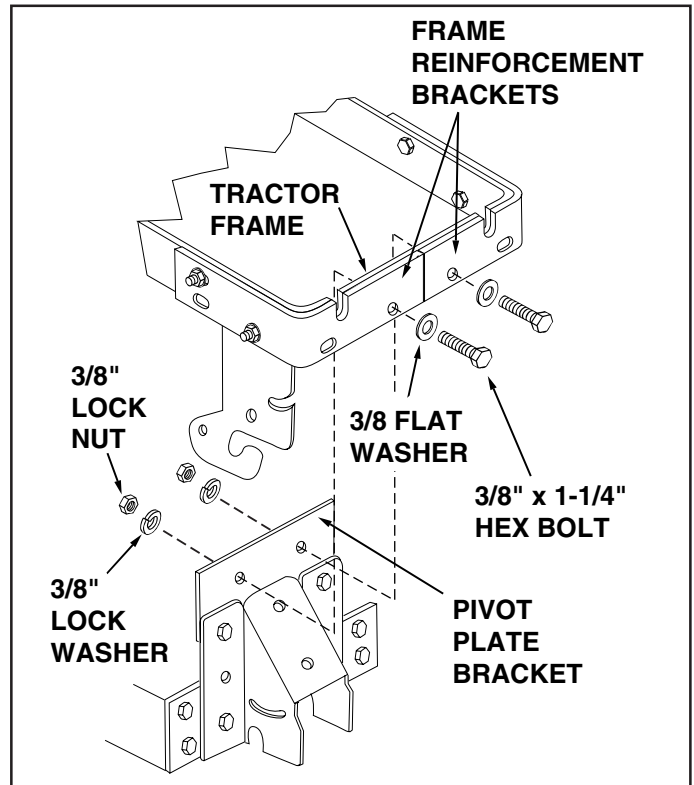

FIGURE 8

- At this time tighten all items previously left untightened.
- Assemble the two angle lock bars together as shown in figure 9 so that all holes are aligned. Use one 3/8" x 1-1/4" carriage bolt, one 3/8" lock washer and one 3/8" hex nut. Be sure to insert bolt from side indicated. **Do not tighten at this time.** See figure 9.

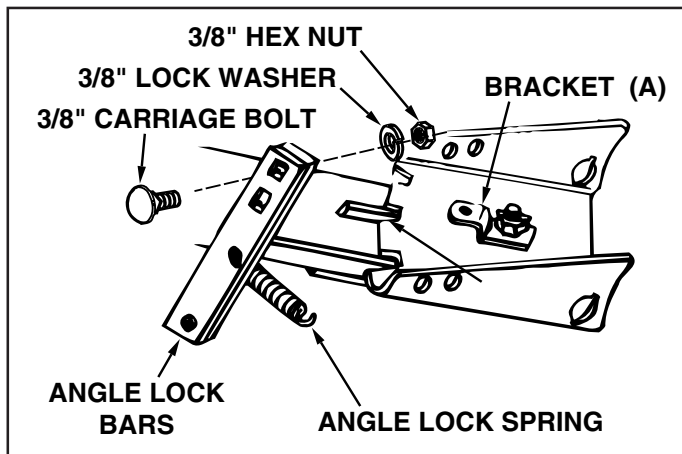

FIGURE 9 (Right Hand Side View)

- Insert straight end of angle lock spring through middle hole in angle lock bars so that hook opening on other end of spring is facing up towards square holes in bars as shown. Assemble hook end of angle lock spring up through bottom of hole in bracket (A). See figures 9 and 10.
- To assemble angle lock bars to channel use one 1/4" x 3-1/4" hex bolt, one hex lock nut and two 1" long spacers. Pull on angle lock bars to extend spring just enough to allow insertion of bars down through slot in channel and pivot bracket. Aligning the spacers on both sides of angle lock bars underneath channel, insert bolt through holes in sides of channel and through the angle lock bars and the two spacers. Assemble the lock nut to the bolt on outside of channel. Tighten so that lock bars pivot freely. See figure 10.
- At this time tighten the 3/8" carriage bolt and hex nut previously assembled to angle lock bars.

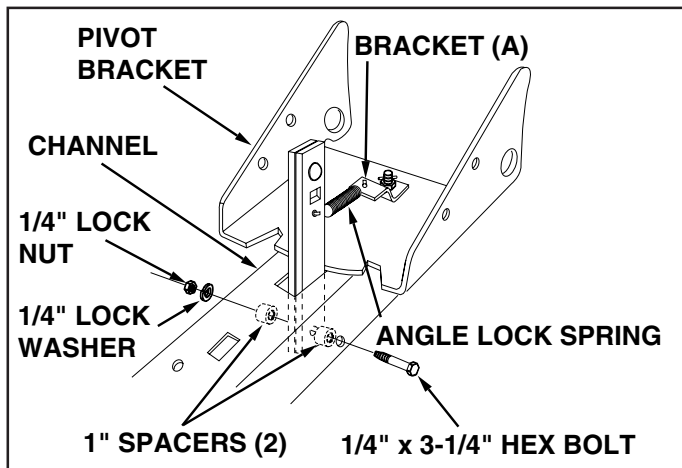

FIGURE 10 (Right Hand Side View)

NOTE: Angle lock bars should pivot freely; and when they are pulled all the way back, the channel/pivot plate assembly should be unlocked and free to pivot to right or left position notches.

- Using a hammer, drive a 3/8" palnut onto one end of spring mount rod. Insert the other end of the spring mount rod through the rear holes on both sides of the pivot plate. Support end (with palnut) of the spring mount rod with a block of wood, and hammer on the remaining palnut. See figure 11.

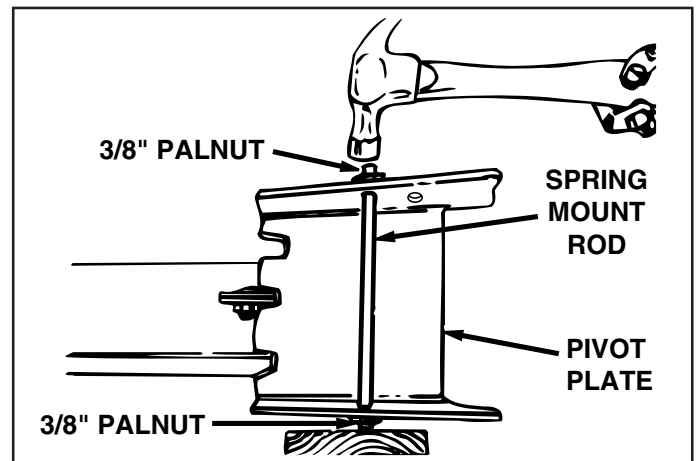

FIGURE 11 (Top View)

- Assemble 3/8" x 1-1/4" carriage bolt through square hole in cable mount bracket and through square hole in angle lock bars. See figures 12 and 13. Note that top bolt faces in opposite direction. Hold cable mount bracket in position as shown in figure 12 and secure with 3/8" lock washer and 3/8" lock nut. **Tighten.** See figures 12 and 13.

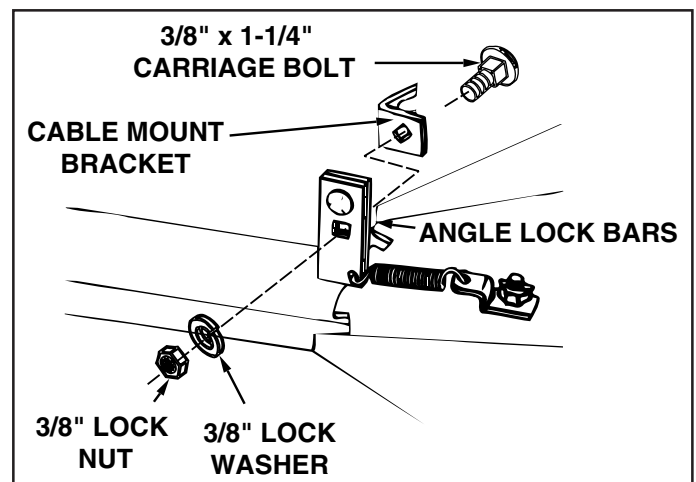

FIGURE 12 (Right Hand Side View)

- Assemble one 5/16 jam nut approximately 3/4" onto threaded end of control cable. Assemble threaded cable end through round hole in cable mount bracket and secure with another 5/16 jam nut. **Tighten**. See figure 13.

NOTE: Some further adjustment may be required after blade assembly is completed.

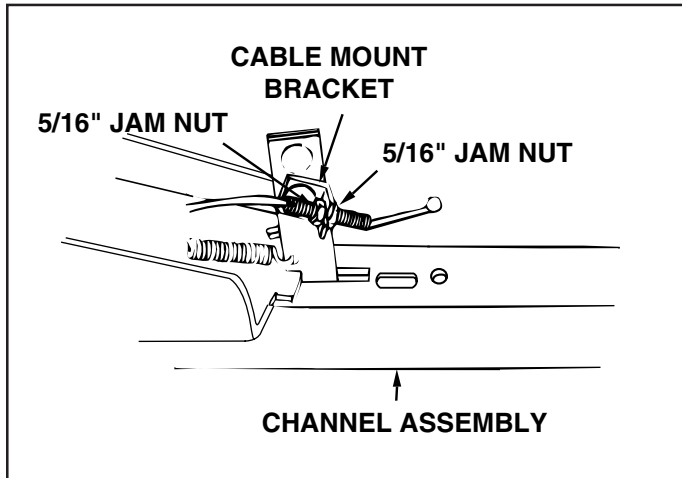

FIGURE 13 (Left Hand Side View)

- Assemble ball end of control cable up through hole in cable end fitting and pull till ball slips inside curled edge of fitting. Note: If ball wont slip under edge of curl it will need to be inserted through open end of curl. See figure 14
- Assemble 1/4" x 1-1/4" hex bolt down through the cable end fitting, the 5/8" long spacer and the left hand hole in the channel assembly. Secure with a 1/4" hex lock nut. See figure 14. **Tighten**.

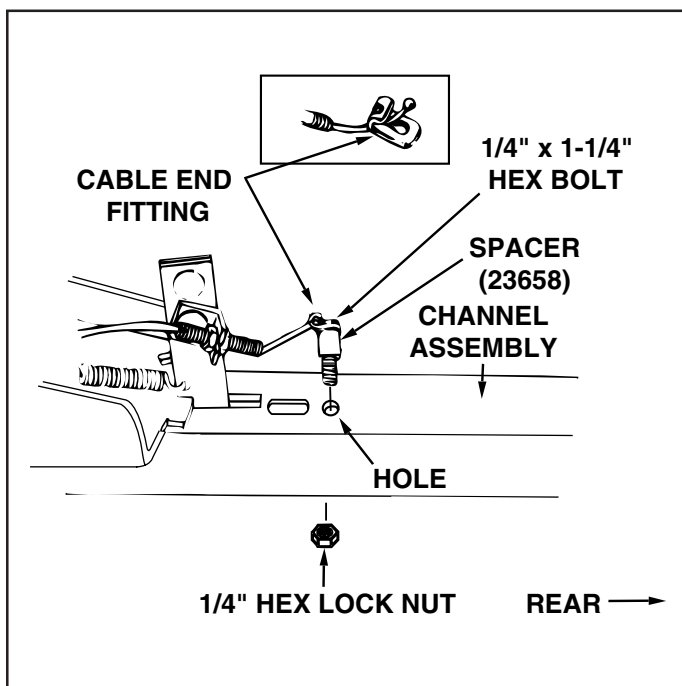

FIGURE 14 (Left Hand Side View)

NOTE: The other end of the control cable will be attached in a later step.

- Attach blade assembly to channel assembly by inserting the blade pivot shaft from the left side (bend facing up) through the notched holes in the blade and channel assemblies. Secure with two 1/8" x 1-1/4" cotter pins through two holes in pivot shaft. Spread ends of pins. See figure 15.
- Hook blade adjust spring over spring mount rod as shown in figure 15. Remove plastic cap, and one 3/8" hex nut from bolt assembled in spring. Adjust the remaining 3/8" hex nut down approximately 1" onto the bolt threads. Assemble bolt up through the hole in top edge of blade and hold in place with the 3/8" hex nut removed earlier. Tighten 3/8" hex nut on top edge of blade down against the bottom 3/8" hex nut. Replace plastic cap over end of bolt threads. See figure 15.

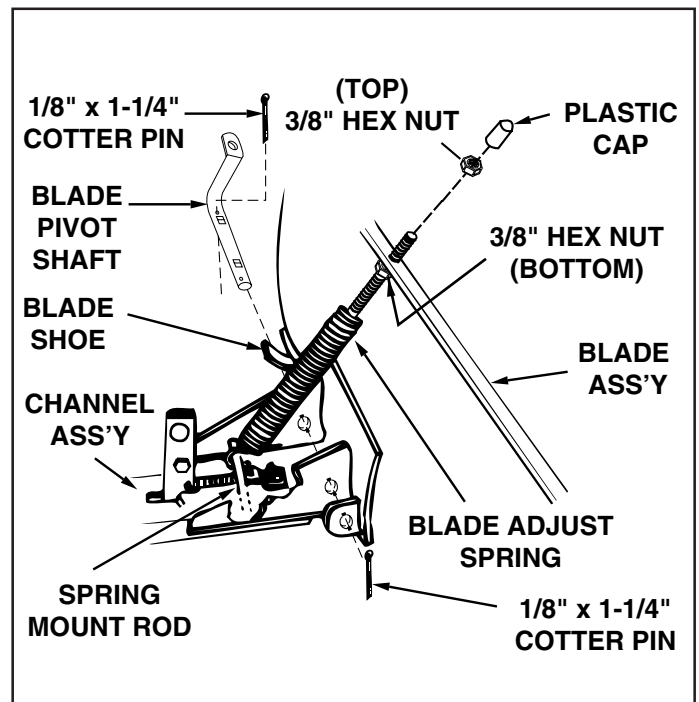

FIGURE 15 (Right Hand Side View)

- Place the end of the channel assembly up inside the pivot support bracket. Align the hole second from the end in the channel assembly with the front hole in the pivot support bracket and secure through from the left side with the channel pivot pin, the 1/2" washer and one hairpin cotter. The hairpin cotter should be pushed all the way through to the loop end. See figure 16.

NOTE: All hairpin cotters on this snow blade should be pushed through to their loop end.

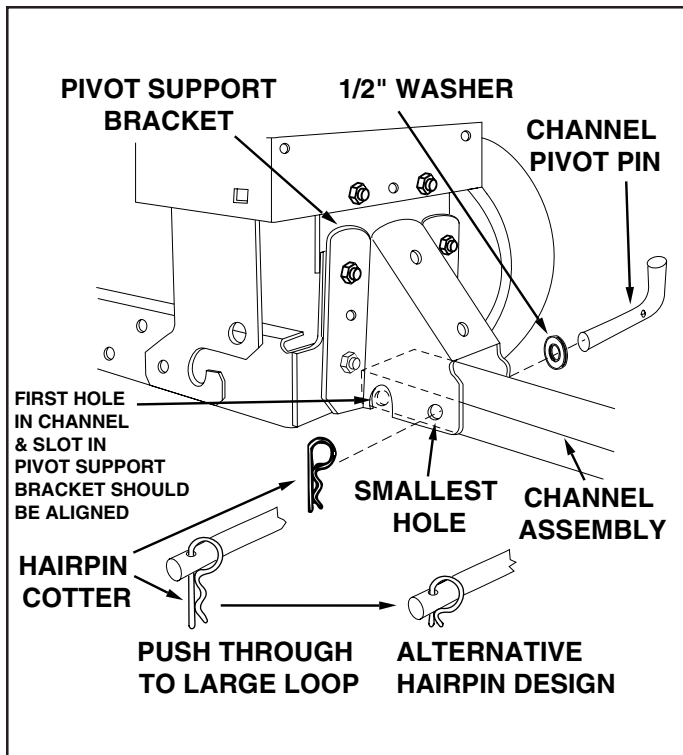

FIGURE 16 (Right Hand Side View)

- To assemble lift handle to blade, assure that holes in end of channel assembly are aligned with clearance slots in sides of pivot support bracket as shown in figure 16. From the left side insert the end of the lift rod through the holes in the channel assembly. Next, align the hole in the lift rod bracket with the lift link which was assembled to the pivot support bracket. Secure with a hairpin cotter inserted up through the cross hole in the lift link pin all the way to the loop end of the hair pin cotter. See figure 17.
- Using the furnished grease packet, apply a light coating of grease to the straight upper portion of the lift rod. Slide lift handle tube onto the lift rod. See figure 17.

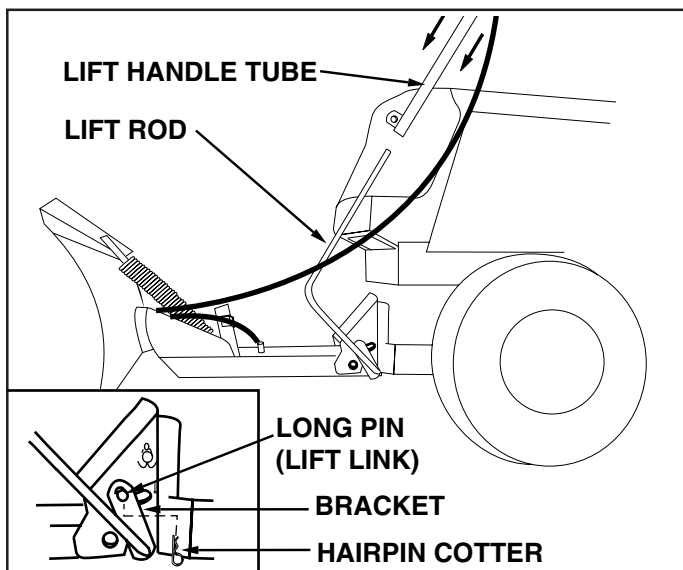

FIGURE 17 (Left Hand Side View)

- To attach loose end of cable to handle assembly, pass cable around outside and underneath handle assembly as shown in figure 17. Mount one 5/16" jam nut approximately 3/4" onto threaded end of control cable. Insert threaded end of cable up through cable mount ear on handle assembly and secure with a second 5/16" jam nut. **Tighten**. See figure 18.

NOTE: Some further adjustment may be required after blade assembly is completed.

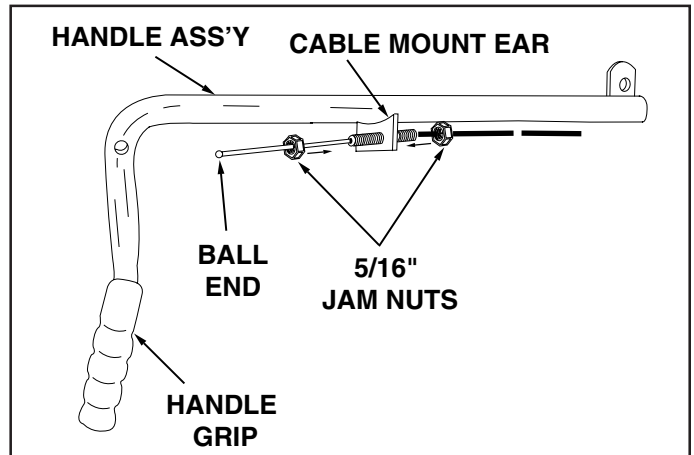

FIGURE 18 (Right Hand Side View)

- Assemble grip assembly to handle assembly using one 5/16" x 1-1/2" hex bolt and one 5/16" hex lock nut. **Do not overtighten** lock nut; grip assembly must pivot freely. See figure 19.
- Assemble ball end of cable to a cable end fitting as was done previously to other end of cable. Secure cable end fitting to handle assembly with a 1/4" hex lock nut. **Do not overtighten** lock nut; cable fitting must pivot freely. See figure 19.

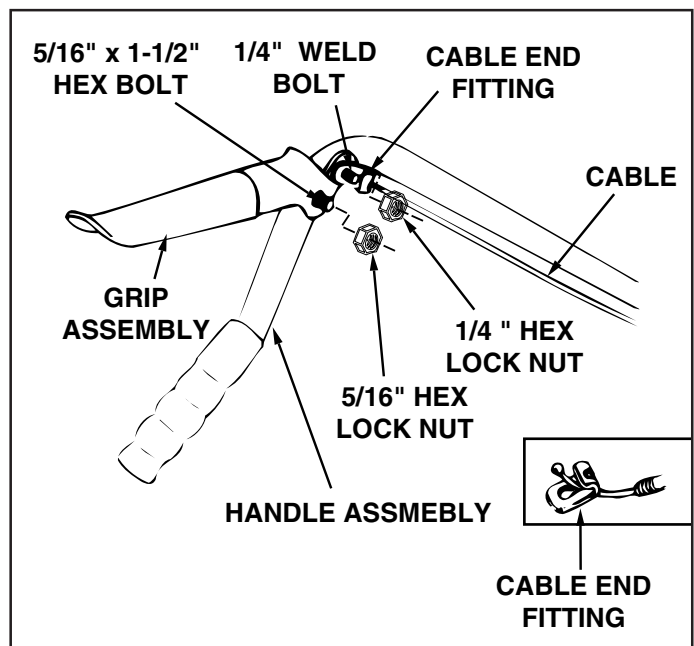

FIGURE 19 (Right Hand Side View)

- Raise the blade to the transport position. (This will require extra effort since the extension spring is not yet attached.)
- Attach the long end of the extension spring to the upper hole in the pivot support bracket and the short end to the center slot in the channel as shown in figure 20.
- Attach the long end of the blade pivot rod down through the blade pivot shaft and the short end of the blade pivot rod to the lift handle tube. Secure both ends with a hairpin cotter pushed through to loop end. See figure 20.
- Use the two plastic ties to hold the cable securely to the outside of the handle tube and away from the tractor to avoid direct heat from the tractor muffler. See figure 20.

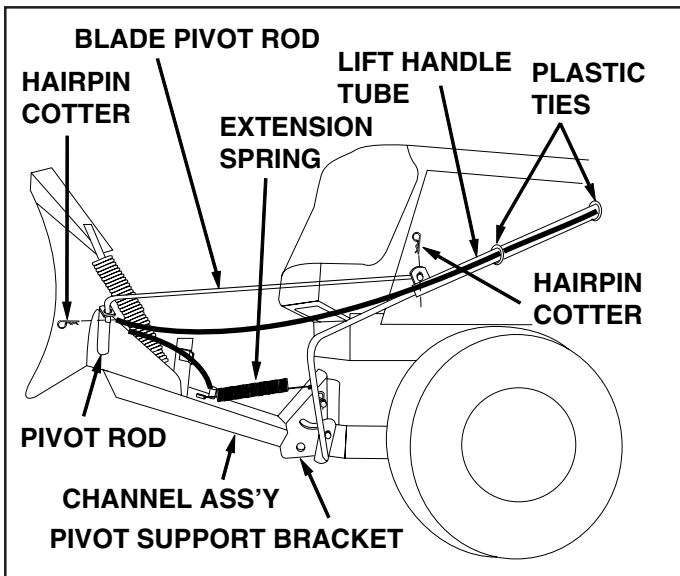

FIGURE 20

(Left Hand Side View)

OPERATION

KNOW YOUR SNOW BLADE

READ THIS OWNER'S MANUAL AND SAFETY RULES BEFORE OPERATING YOUR SNOW BLADE.

Compare the illustration below with your snow blade to familiarize yourself with the various controls and their locations.

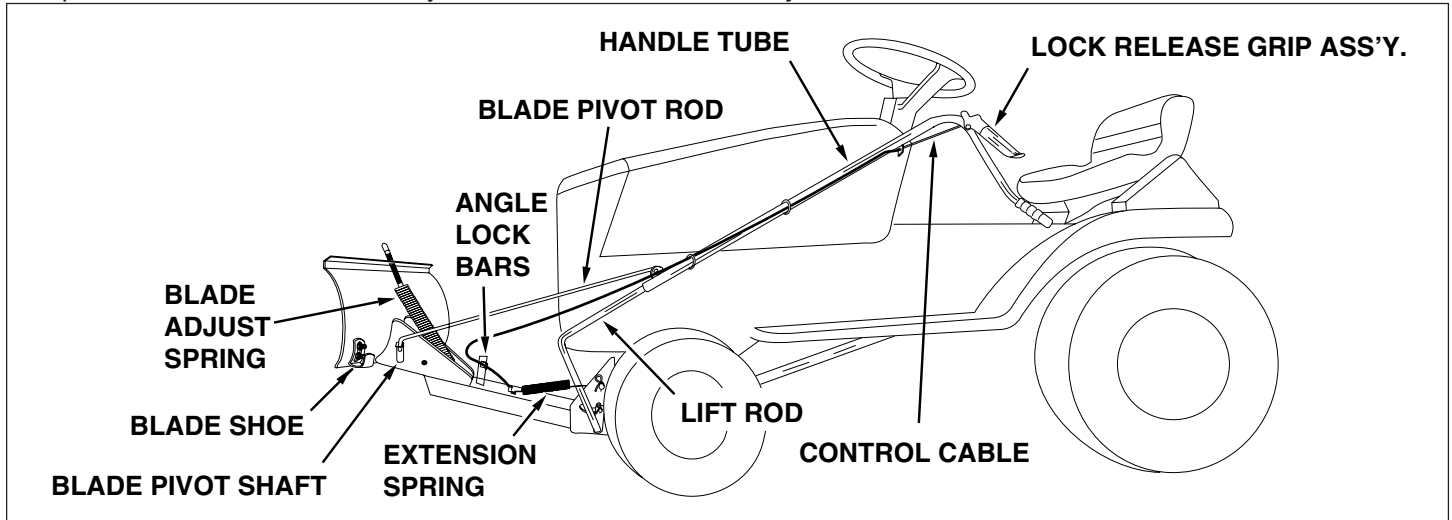

LOCK RELEASE GRIP ASS'Y.	Unlocks the blade to swivel to the right and left.
HANDLE TUBE	Raises or lowers the blade and pivots blade to the right and left.
BLADE PIVOT ROD	Connects blade to handle tube. Pivots blade to the right and left.
ANGLE LOCK BARS	Locks the blade in either the right hand, left hand or straight ahead position.
BLADE ADJUST SPRING	Holds blade in position but permits it to pivot forward to pass over an obstruction.
BLADE SHOE	Ground contacting part of blade. Adjusts for adequate ground clearance of blade.
BLADE PIVOT SHAFT	Connects blade to channel assembly. Allows blade to pivot forward.
EXTENSION SPRING	Makes blade easier to raise by helping to counter the weight of the blade.
LIFT ROD	Connects blade channel to the handle tube. Raises and lowers the blade.
CONTROL CABLE	Connects the lock release lever to the angle lock bars.

HOW TO USE YOUR SNOW BLADE

To Lift or Lower the Snow Blade

- Use the handle grip located on the on the end of the handle tube. To raise the blade, pull back while pushing down on the handle grip. To lower blade, pull back while lifting up on handle grip. See figure 21.

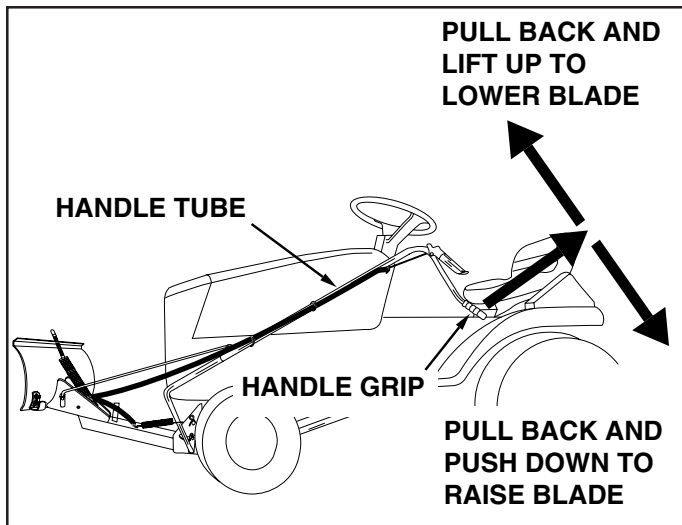

FIGURE 21

To Pivot the Blade

- Raise blade to transport position. Push the lock release grip down against the handle tube to unlock the blade. To pivot the blade, keep the grip depressed and push forward or pull back on the handle tube sliding it along the lift rod. Release the grip to lock the blade when it is in either the right hand, the left hand or the straight ahead position. See figure 22.

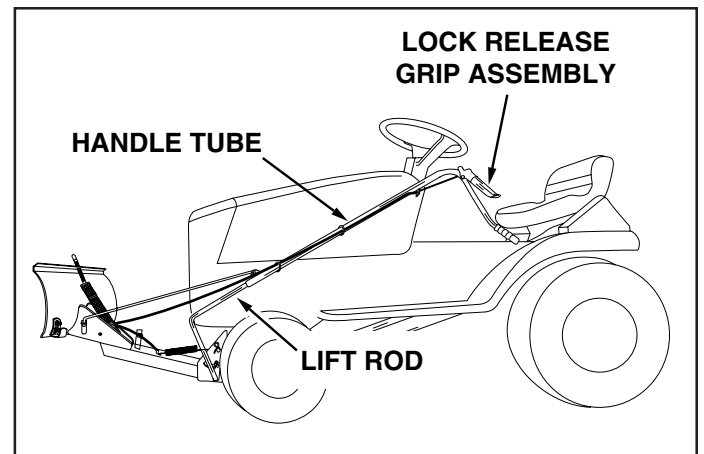

FIGURE 22

OPERATION

NOTE: Wheel weights and tire chains must be used with your snow blade for traction.



CAUTION: INSPECT THE AREA TO BE WORKED CAREFULLY BEFORE OPERATING THE SNOW BLADE. AVOID PIPES, ROOTS, CURBS OR OTHER HEAVY OBSTRUCTIONS.



CAUTION: KNOW THE TERRAIN. AVOID EXCEPTIONALLY STEEP SLOPES OR DROP OFFS WHICH MAY BE HIDDEN BY THE SNOW. NEVER RUN THE SNOW BLADE INTO HEAVY MATERIAL AT HIGH SPEED.

Using the Snowblade

- Prepare lawn tractor engine for cold weather using instructions furnished with the lawn tractor.
- Always begin with transmission in first (low) gear and gradually increase speed as required.
- DO NOT repeatedly push snow in the same direction causing excessive build up with each successive pass.
- To reduce icing on blade, allow lawn tractor and blade to adjust to outdoor temperature before operating.



CAUTION: ALWAYS LOWER BLADE TO GROUND BEFORE LEAVING TRACTOR.

CUSTOMER RESPONSIBILITIES

Lubrication Points

- Lubricate the points shown in figure 23 for easier operation. Use the grease packet furnished with the snow blade for lubrication of the lift handle rod and the lift handle tube assemblies.

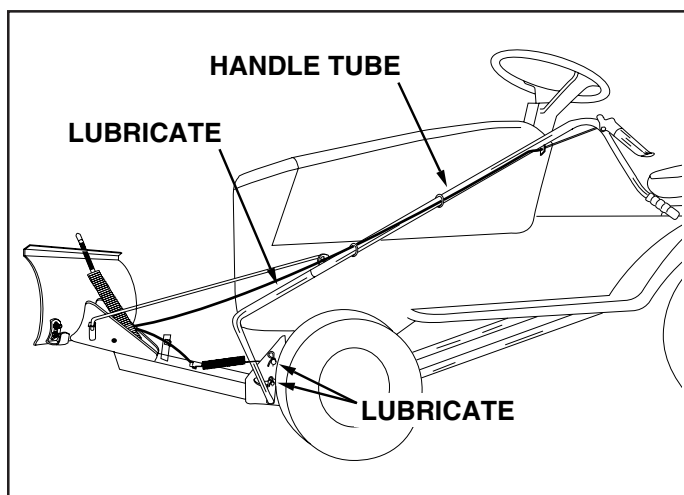

FIGURE 23

Maintenance

- During the operating season, check all bolts, nuts and hairpin cotter pins to be sure they are secure. For improved snow removal performance, coat the blade with automotive type paste wax.

SERVICE AND ADJUSTMENTS

To Adjust Blade Spring

- The tension of the blade adjust spring is adjustable to permit blade to tilt forward to by-pass solid obstructions. To change spring tension (standing in front of blade assembly), adjust the nuts at upper end of the spring bolt, turning counter clockwise to relieve tension and clockwise to increase tension. See figure 15 on page 8.

To Adjust Blade Shoes

- Blade shoes on ends of blade may be raised for close work on smooth surfaces or lowered to raise the blade to work on rough or uneven areas. Make sure both shoes are set evenly and nuts are tightened securely. See figure 24.

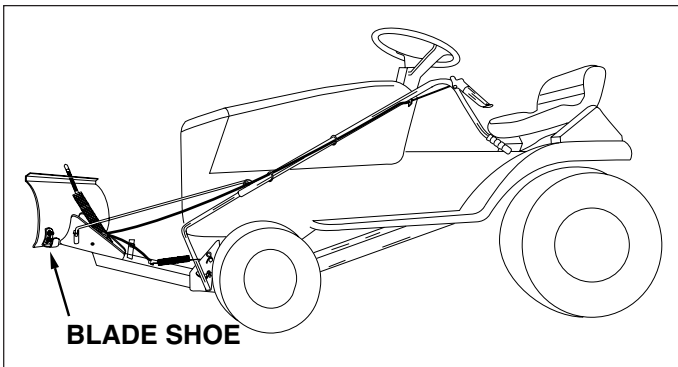

FIGURE 24

To Adjust the Blade Pivot Lock Mechanism

- If the blade will not unlock and pivot, the angle lock bars are not disengaging from slots in pivot plate. To correct this condition, adjust the 5/16" hex jam nuts to draw the end of the control cable back towards the welded cable mount ear on the handle tube. The less the end of the cable extends through the ear, the more the angle lock bars can retract to disengage from the slots in the pivot plate. See figure 25.

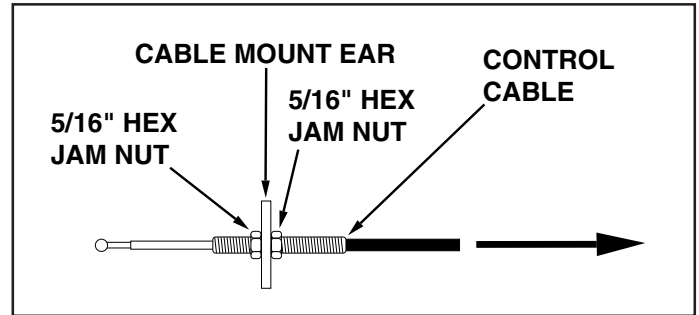

FIGURE 25

STORAGE

Recommendations When Storing

- When the snow blade is not being used, remove all dirt and rust and touch up with paint.
- Apply a light coat of grease or rust preventive to the blade and oil all pivot points.
- Store in an area where it is protected from weather.

To Remove Blade From Tractor

- Lower blade to ground with blade in the center (straight) position.
- Refer to figure 20 on page 10.
 - Remove 3/32" hairpin cotter from lower end of blade pivot rod.
 - Remove 3/32" hairpin cotter from welded link on lift rod and remove control tube assembly.
 - Remove 3/32" hairpin cotter from channel pivot pin and remove channel pivot pin.

TROUBLESHOOTING POINTS

Blade is difficult to raise.	<ol style="list-style-type: none"> 1. Extension spring is broken/missing. 2. Lift mechanism is binding 	<ol style="list-style-type: none"> 1. Replace or reinstall. See page 10. 2. Lubricate as instructed on page 12.
Blade is difficult to pivot.	<ol style="list-style-type: none"> 1. Handle tube is binding on lift rod. 2. Loose flow control gauge 	<ol style="list-style-type: none"> 1. Lubricate handle tube and lift rod as instructed on page 12.
Blade will not pivot.	<ol style="list-style-type: none"> 1. Lock mechanism is not disengaging. 	<ol style="list-style-type: none"> 1. Adjust the pivot lock mechanism as instructed on page 13.

REPAIR PARTS FOR MODEL LBD48C - 48" SNOW BLADE

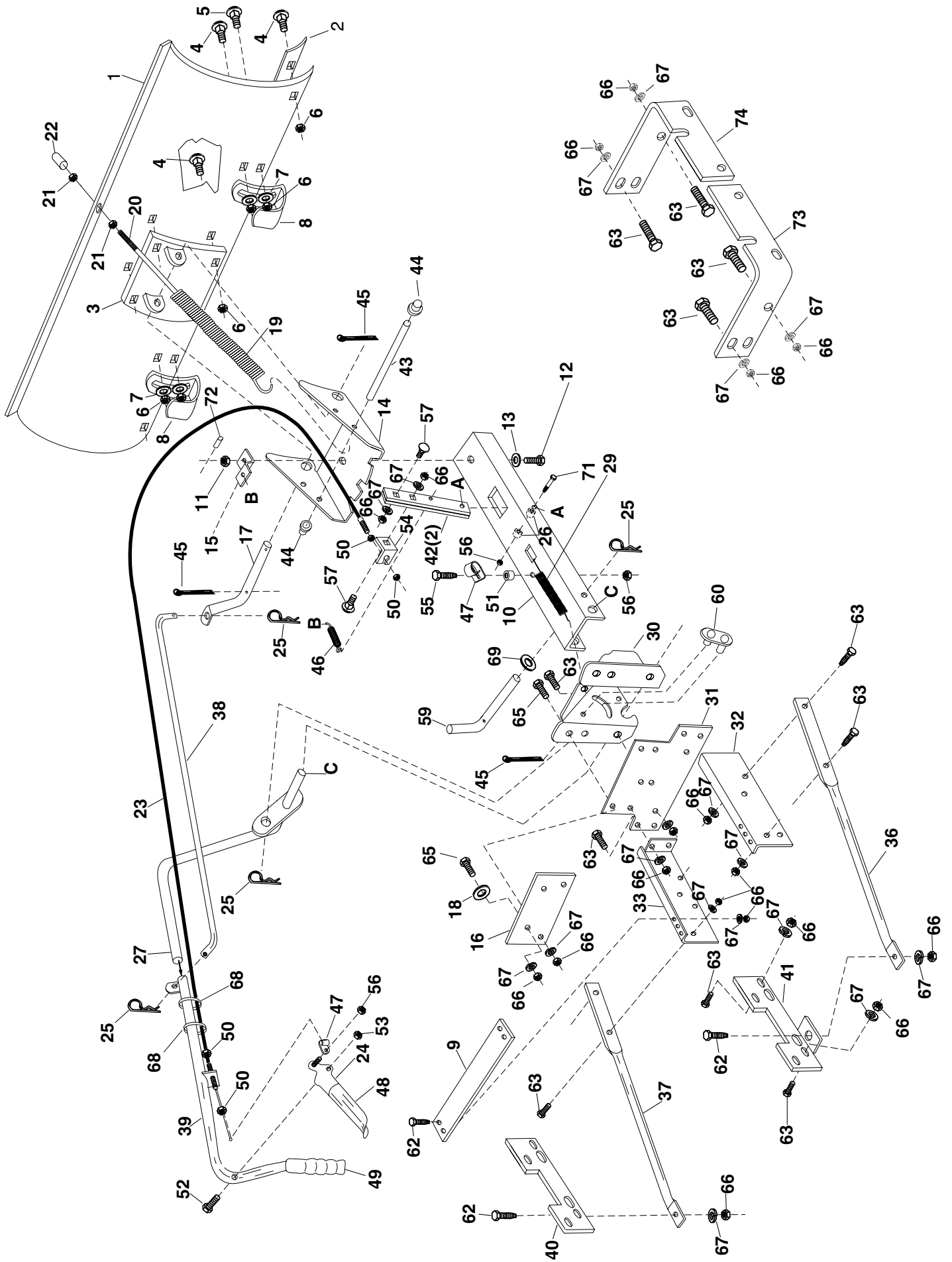

REPAIR PARTS LIST FOR MODEL LBD48C - 48" SNOW BLADE

REF. NO.	PART NO.	QTY.	DESCRIPTION	REF. NO.	PART NO.	QTY.	DESCRIPTION
1	23955	1	Blade 48"	38	46049	1	Rod, Blade Pivot
2	23956	1	Wear Plate 48"	39	62972	1	Ass'y Lift Handle Tube
3	62980	1	Reinforcement Plate Ass'y	40	23967	1	Bracket, Brace Mount (rear) (LH)
4	43080	10	Bolt, Carriage 5/16-18 x 3/4"	41	23968	1	Bracket, Brace Mount (rear) (RH)
5	43079	2	Bolt, Carriage 5/16-18 x 1"	42	23151	2	Angle Lock Bar
6	43064	11	Nut, Hex Lock 5/16-18	43	23856	1	Spring Mount Rod
7	43081	4	Washer, 5/16"	44	44917	2	Palnut, 3/8"
8	23070	2	Skid Shoe	45	43010	3	Cotter Pin 1/8" x 1-1/4"
9	23970	1	Brace, Cross	46	43348	1	Angle Lock Spring
10	62970	1	Ass'y channel Sub	47	746-0260	2	Cable End Fitting
11	43262	1	Nut, Hex Lock 1/2-13	48	731-0869	1	Grip, Plastic
12	23131	1	Bolt, Special Pivot	49	7071	1	Handle, Grip 3/4"
13	43352	1	Washer, Flat 7/16"	50	712-0256	4	Hex Jam Nut 5/16 Thread
14	23958	1	Plate, Pivot 7 Ga.	51	23658	1	Spacer, 9/16" O.D. x 5/8" Lg.
15	23130	1	Bracket, Spring Mt.	52	43085	1	Hex Bolt, 5/16-18 x 1-1/2"
16	23966	1	Bracket, Pivot Plate	53	43064	1	Hex Lock Nut 5/16-18 Thread
17	46066	1	Shaft, Blade Pivot	54	05762	1	Cable Mount Bracket
18	43070	2	Washer 3/8" STD.	55	1509-90	1	Hex Bolt 1/4-20 x 1-1/4"
19	9466R	1	Spring, Blade Adjust	56	43013	3	Hex Lock Nut 1/4-20 Thread
20	44071	1	Bolt, Hex 3/8-16 x 3-1/2"	57	710-0305	2	Carriage Bolt 3/8-16 x 1-1/4"
21	43015	2	Nut, Hex 3/8-16	59	46065	1	Channel Pivot Pin
22	44074	1	Plastic Cap	60	63034	1	Lift Link Ass'y
23	746-0366	1	Control Cable Ass'y	62	43407	6	Bolt, Hex 3/8-16 x 3/4"
24	62561	1	Release Grip Ass'y	63	43001	18	Hex Bolt 3/8-16 x 1"
25	43055	4	Pin, Hairpin Small 3/32"	65	43087	4	Hex Bolt 3/8-16 x 1-1/4"
26	46053	2	Spacer, 9/16" O.D. x 1" Lg.	66	43082	30	Hex Lock Nut 3/8-16 Thread
27	63033	1	Lift Handle Rod Ass'y	67	43003	30	Lock Washer 3/8"
29	732-0153	1	Extension Spring	68	726-0178	2	Plastic Tie
30	24023	1	Pivot Support Bracket	69	R19171616	1	Washer
31	23960	1	Plate, Pivot Support	71	46071	1	Bolt, Hex 1/4-20 x 3-1/4" Lg. Gr. 5
32	23962	1	Frame Pivot Support (RH)	72	43349	1	1/4" x 1" Spring Pin
33	23961	1	Frame Pivot Support (LH)	73	24164	1	Bracket, Frame Reinforcement, R.H.
36	46048	1	Brace, Tube (RH)	74	24165	1	Bracket, Frame Reinforcement, L.H.
37	46047	1	Brace Tube (LH)		46864	1	Owners Manual

