

Quick Start Guide

45-06141 Push Spreader

Read the manual that came with your Push Spreader for:

- Important safety warnings
- Further explanation of features
- Operating instructions and flow control adjustments

Problem?
Call 1-800-448-9282



Quick Start Guide

45-06141 Push Spreader

Read the manual that came with your Push Spreader for:

- Important safety warnings
- Further explanation of features
- Operating instructions and flow control adjustments

Problem?
Call 1-800-448-9282



CARTON CONTENTS

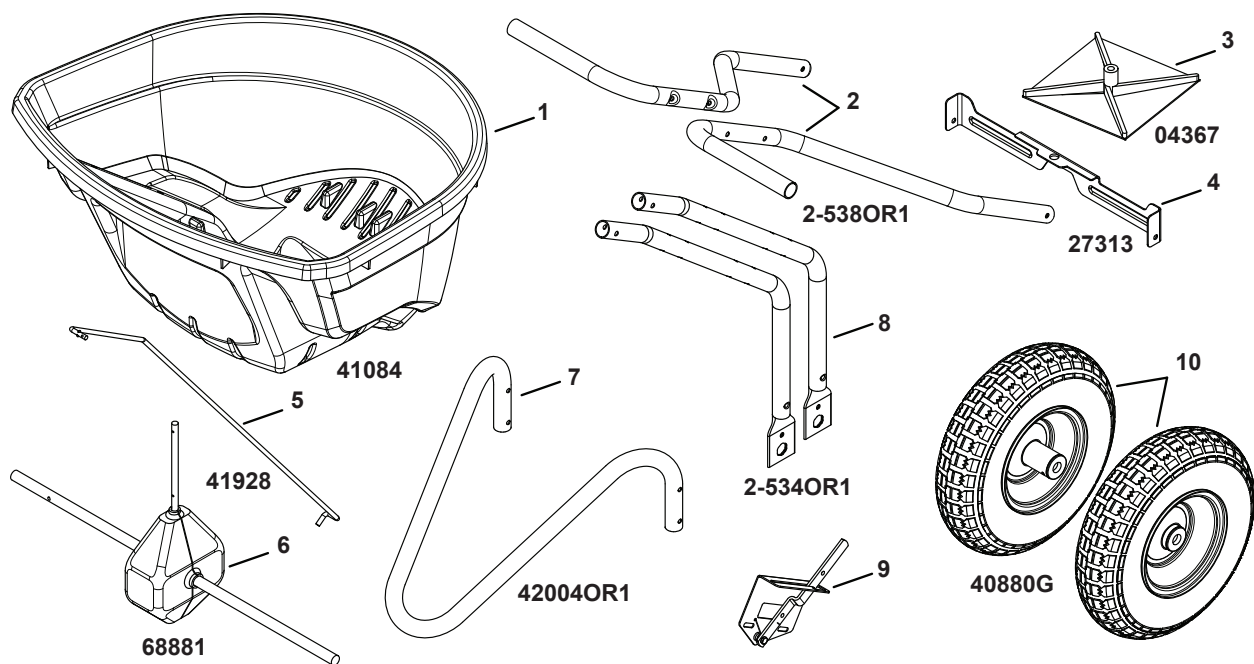

HARDWARE PACKAGE

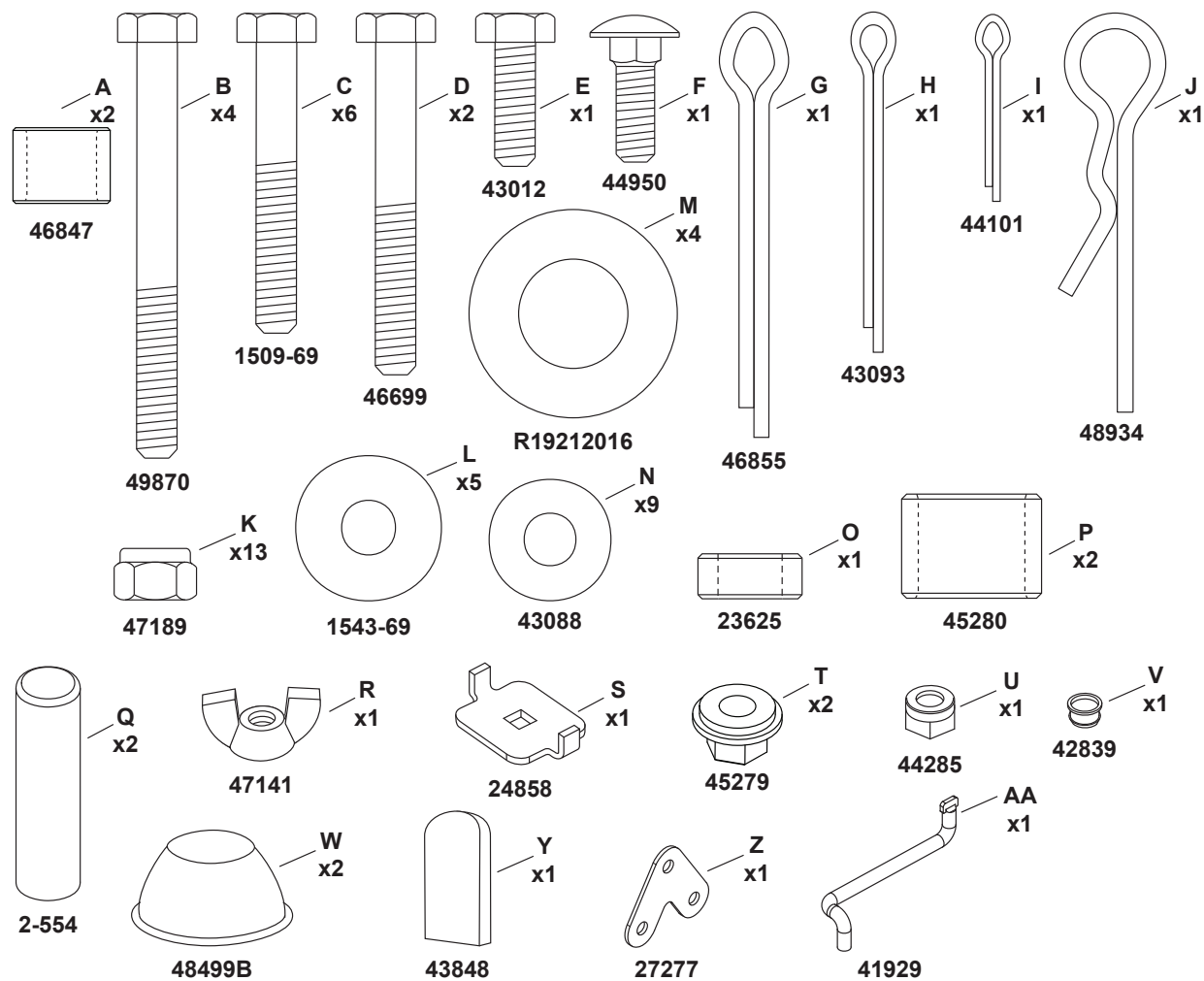

TOOLS REQUIRED FOR ASSEMBLY

- (1) Hammer
- (1) Pliers
- (2) 7/16" Wrenches

STEP 1: (SEE FIGURE 1)

- Press the hex bushings (T) into the hex holes in the bottom of the hopper support tubes (8).
- Slide the hopper support tubes (8) onto the gearbox axle.

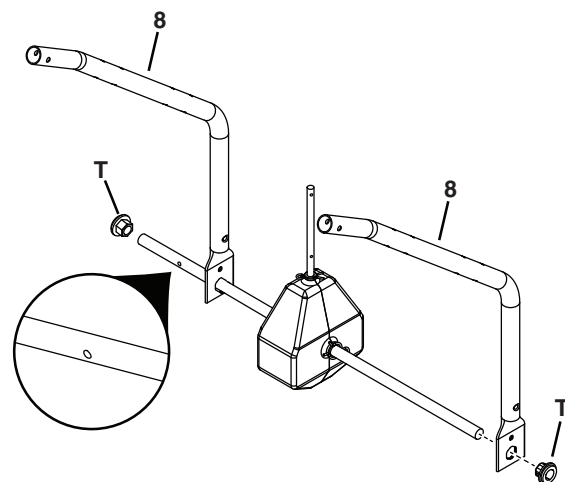

Figure 1

STEP 2: (SEE FIGURE 2)

- Install the stand tube (7) between the hopper support tubes as shown, using two 1/4" x 2" hex bolts (D), spacers (A), and 1/4" nylock nuts (K). Place the spacers between the hopper support tubes and the stand tube. **Do not tighten completely.**

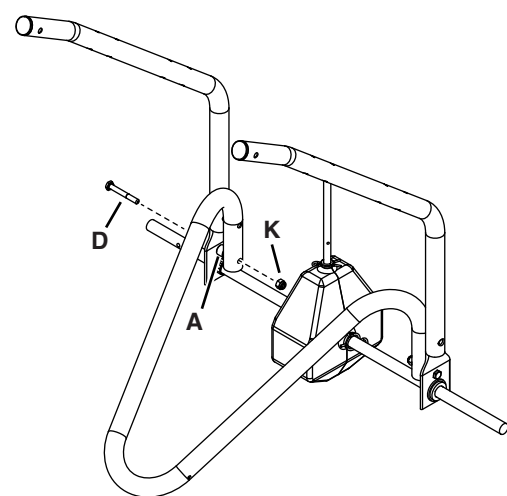

Figure 2

STEP 3: (SEE FIGURE 3)

- Secure together the stand tube (7) and hopper support tubes (8) as shown, using two 1/4" x 2-1/2" hex bolts (B) and 1/4" nylock nuts (K). **Do not tighten completely.**

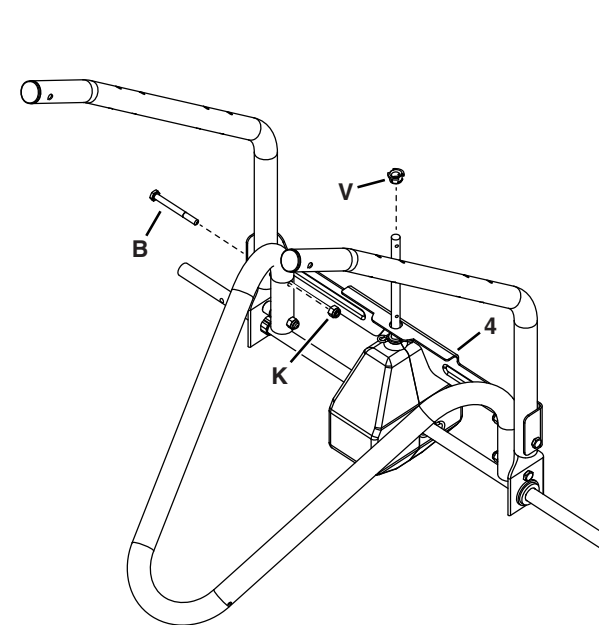

Figure 3

STEP 4: (SEE FIGURE 4)

- Slide the spreader impeller (3) onto the spreader shaft and secure it with a 1/8" x 1-1/2" cotter pin (H) by spreading the ends of the cotter pin.

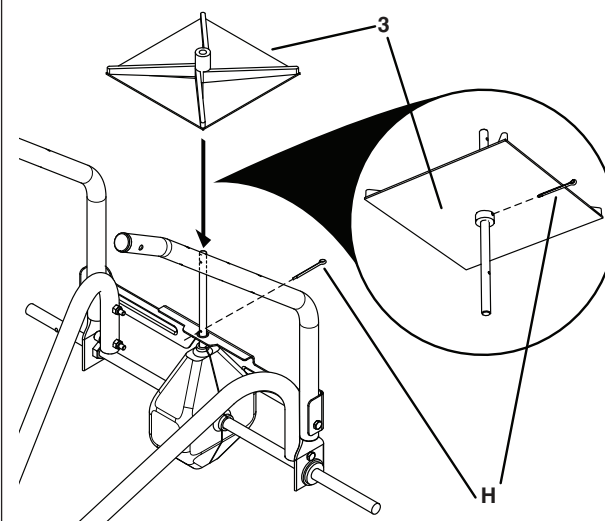

Figure 4

STEP 5: (SEE FIGURE 5)

- Install the flattened end of the drive link rod (AA) into the hole in the flow plate. Twist the rod to lock it in the flow plate.

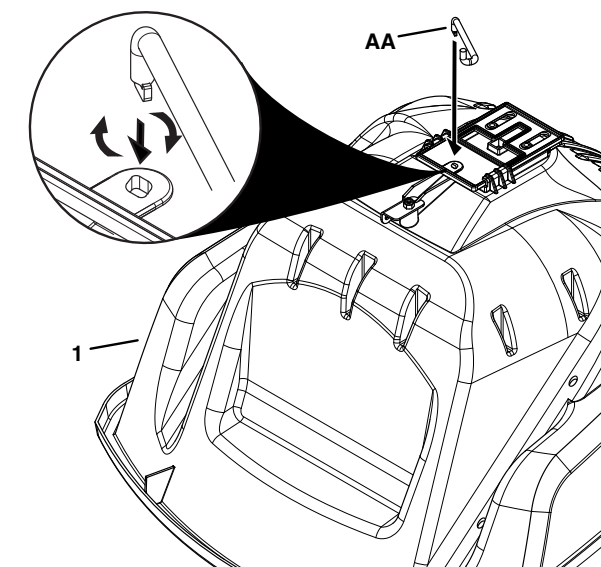

Figure 5

STEP 6: (SEE FIGURE 6)

- Install the drive link bracket (Z) onto the end of the drive link rod (AA).
- Attach the drive link bracket (Z) to the bracket already attached to the bottom of the hopper using a 1/4" x 3/4" hex bolt (E) and a 1/4" nylock nut (K). Tighten the nut and then back it off 1/4 to 1/2 turn.

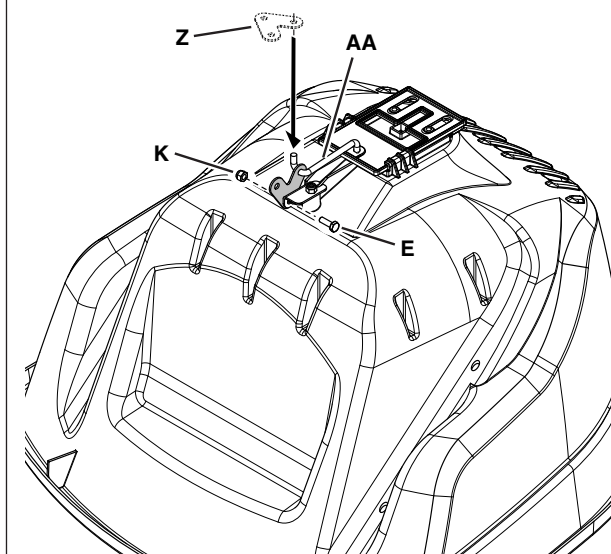

Figure 6

- Important safety warnings
- Further explanation of features
- Operating instructions and flow control adjustments

- Important safety warnings
- Further explanation of features
- Operating instructions and flow control adjustments

STEP 7: (SEE FIGURE 7)

- Place the hopper on the hopper support tubes, inserting the spreader shaft up through the square hole in the bottom of the hopper.
- Slide the hopper bushing (U) onto the spreader shaft and insert it into the bottom of the hopper.
- Slide the spacer (O) onto the spreader shaft.
- Install the agitator hairpin (J) in the spreader shaft.

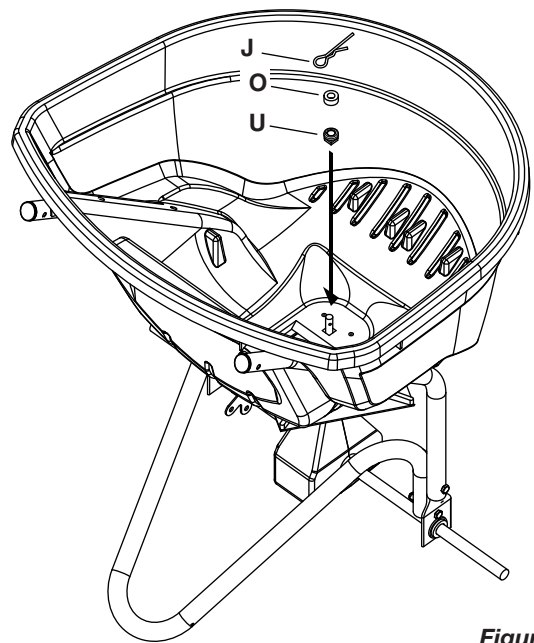

Figure 7

STEP 8: (SEE FIGURE 8)

- Attach the hopper to the upper holes in the hopper support tubes using four 1/4" x 1-3/4" hex bolts (C), 1/4" washers (N), nylon washers (L) and 1/4" nylock nuts (K). **Tighten.**
- **Tighten** the bolts and nuts assembled in steps 2 and 3.

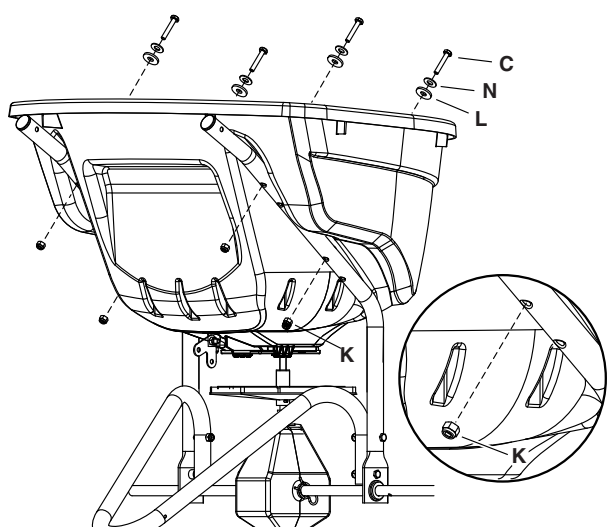

Figure 8

STEP 9: (SEE FIGURE 9)

- Slide a 5/8" washer (M), a spacer (P), a 5/8" washer (M) and a wheel (10) onto the end of the axle with a hole.
- Secure the wheel to the axle with a 3/16" x 2" cotter pin (G), spreading the ends of the cotter pin.
- Using a hammer, carefully tap a hub cap (W) onto the axle.

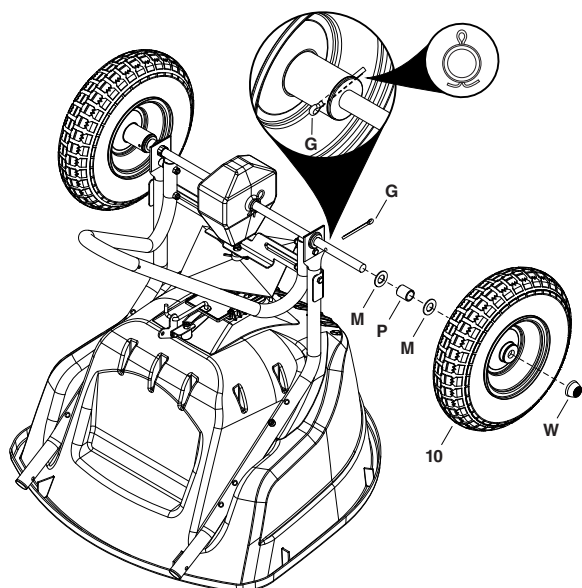

Figure 9

STEP 10: (SEE FIGURE 10)

- Slide a 5/8" washer (M), a spacer (P), a 5/8" washer (M) and a wheel (10) onto the end of the axle without a hole.
- Using a hammer, carefully tap a hub cap (W) onto the axle.

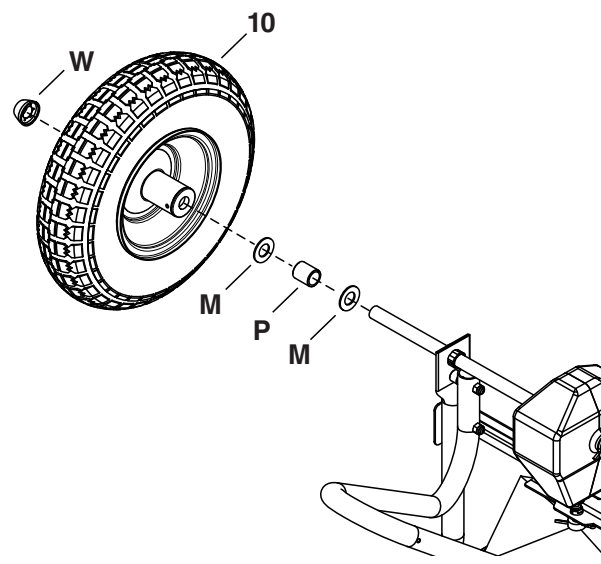

Figure 10

STEP 11: (SEE FIGURE 11)

- Attach the handle tubes (2) to the hopper support tubes using two 1/4" x 1-3/4" hex bolts (C), and 1/4" nylock nuts (K). **Tighten.**

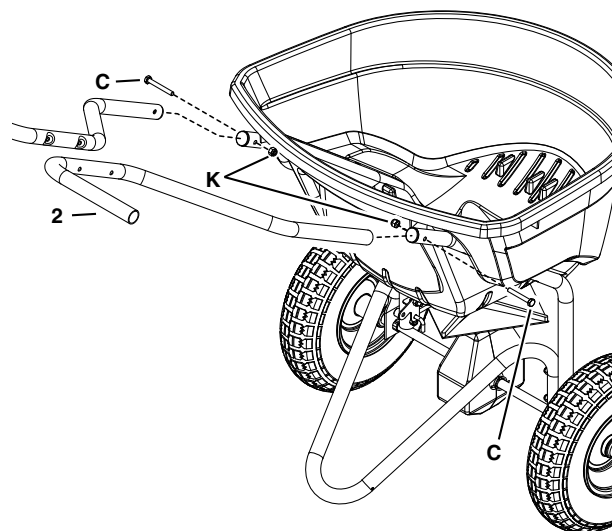

Figure 11

STEP 12: (SEE FIGURE 12)

- Attach the flow control bracket (9) to the handle tubes using two 1/4" x 2-3/4" hex bolts (B), four 1/4" washers (N) and two 1/4" nylock nuts (K). **Do not tighten yet.**

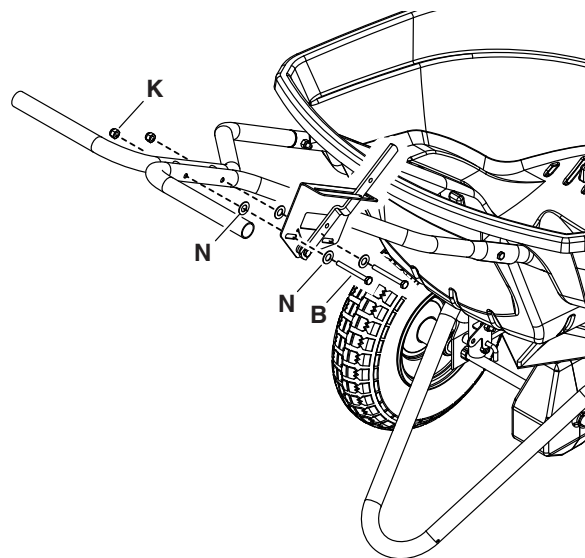

Figure 12

STEP 13: (SEE FIGURE 13)

- Insert the lower end of the flow control rod (5) through the hole in the drive link bracket (Z) and then twist the rod so that the end points down.

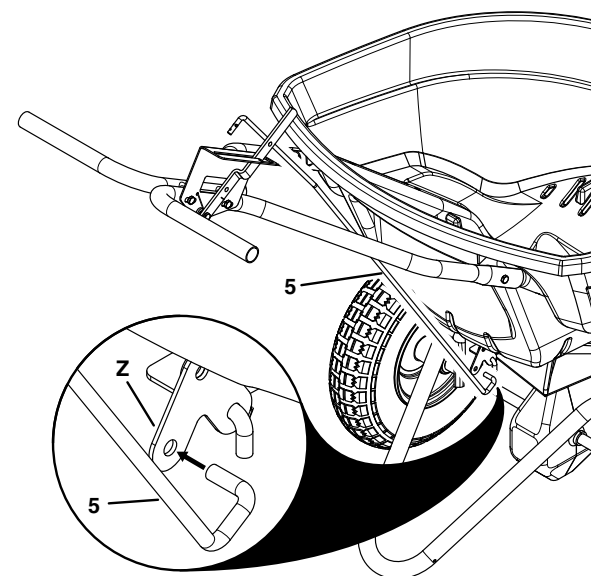

Figure 13

STEP 14: (SEE FIGURE 14)

- Insert the upper end of the flow control rod (5) through the hole in the flow control arm. Secure it with a 1/4" washer (N) and a 3/32" x 3/4" cotter pin (I), spreading the ends of the cotter pin.

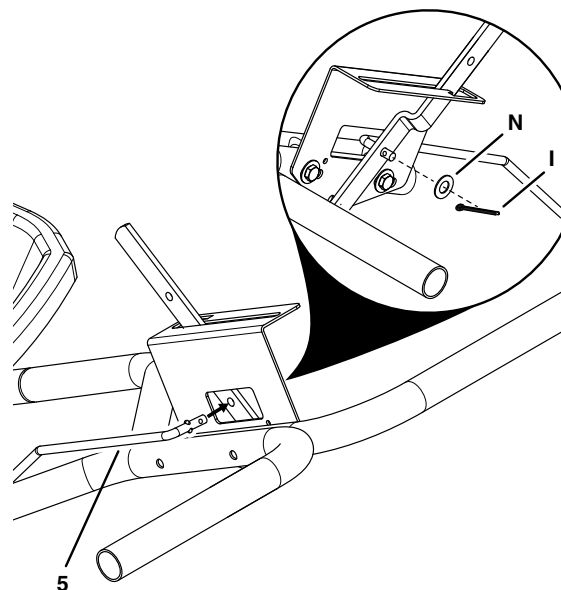

Figure 14

STEP 15: (SEE FIGURE 15)

- Install the grip (Y) onto the flow control arm.
- Install the handle grips (Q) onto the handles.
- Assemble the adjustable stop (S) to the flow control bracket using the 1/4" x 3/4" carriage bolt (F), nylon washer (L) and wing nut (R).

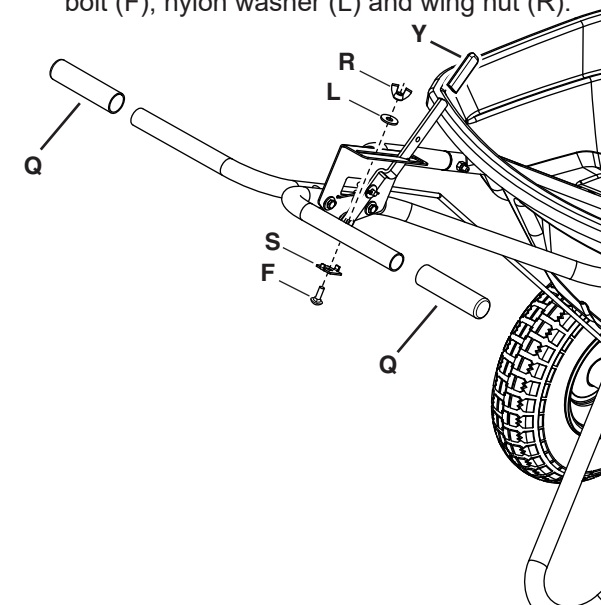

Figure 15

STEP 16: (SEE FIGURE 16)

- Move the control lever to the "OFF" position.
- Slide the control bracket along the control tube until the shut-off plate in the bottom of the hopper is closed.
- Lightly tighten the hex nuts that fasten the flow control bracket to the control tube.
- Set the adjustable stop at "5". Pull the control lever against the stop and verify that the shut-off plate has opened about half way.
- If the shut-off plate does not open half way, adjust the position of the control bracket until the shut-off plate opens half way and closes completely.
- Tighten the hex nuts.

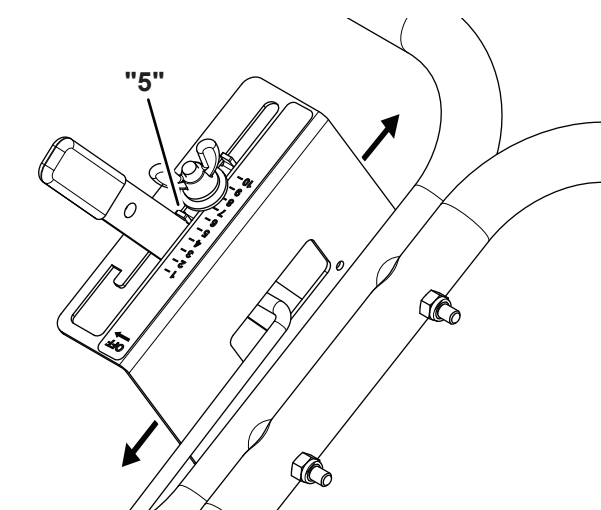

Figure 16